

**3103 Gas Valve with
EM-35MR Electric Powered Actuator**

Installation and Operation Manual

IMPORTANT



This is the safety alert symbol. It is used to alert you to potential personal injury hazards. Obey all safety messages that follow this symbol to avoid possible injury or death.

DEFINITIONS

- **DANGER**—Indicates a hazardous situation which, if not avoided, will result in death or serious injury.
- **WARNING**—Indicates a hazardous situation which, if not avoided, could result in death or serious injury.
- **CAUTION**—Indicates a hazardous situation which, if not avoided, could result in minor or moderate injury.
- **NOTICE**—Indicates a hazard that could result in property damage only (including damage to the control).
- **IMPORTANT**—Designates an operating tip or maintenance suggestion.

WARNING

The engine, turbine, or other type of prime mover should be equipped with an overspeed shutdown device to protect against runaway or damage to the prime mover with possible personal injury, loss of life, or property damage.

The overspeed shutdown device must be totally independent of the prime mover control system. An overtemperature or overpressure shutdown device may also be needed for safety, as appropriate.



Read this entire manual and all other publications pertaining to the work to be performed before installing, operating, or servicing this equipment. Practice all plant and safety instructions and precautions. Failure to follow instructions can cause personal injury and/or property damage.



This publication may have been revised or updated since this copy was produced. To verify that you have the latest revision, be sure to check the *publications page* on the Woodward website:

www.woodward.com/searchpublications.aspx

The current revision and distribution restriction of all publications are shown in manual **26311**.

The latest version of most publications is available on the *publications page*. If your publication is not there, please contact your customer service representative to get the latest copy.



Any unauthorized modifications to or use of this equipment outside its specified mechanical, electrical, or other operating limits may cause personal injury and/or property damage, including damage to the equipment. Any such unauthorized modifications: (i) constitute "misuse" and/or "negligence" within the meaning of the product warranty thereby excluding warranty coverage for any resulting damage, and (ii) invalidate product certifications or listings.

NOTICE

To prevent damage to a control system that uses an alternator or battery-charging device, make sure the charging device is turned off before disconnecting the battery from the system.

NOTICE

To prevent damage to electronic components caused by improper handling, read and observe the precautions in Woodward manual **82715**, *Guide for Handling and Protection of Electronic Controls, Printed Circuit Boards, and Modules*.

■ Revisions—Text changes are indicated by a black line alongside the text.

Woodward reserves the right to update any portion of this publication at any time. Information provided by Woodward is believed to be correct and reliable. However, no responsibility is assumed by Woodward unless otherwise expressly undertaken.

Contents

REGULATORY COMPLIANCE	III
ELECTROSTATIC DISCHARGE AWARENESS	V
CHAPTER 1. GENERAL INFORMATION.....	1
Introduction	1
3103 Gas Valve	1
EM-35MR Actuator	2
Resolver.....	2
Applications	2
CHAPTER 2. INSTALLATION.....	3
Unpacking.....	3
Power Requirements	3
EM Actuator/3103 Gas Valve Installation.....	8
Piping Installation	8
Electrical Connections.....	9
CHAPTER 3. DESCRIPTION OF OPERATION	12
EM-35MR Actuator	12
3103 Gas Valve	12
CHAPTER 4. ACTUATOR/VALVE CALIBRATION	13
EM-35MR Actuator/3103 Gas Valve with Driver	13
CHAPTER 5. TROUBLESHOOTING AND FIELD REPLACEMENT	15
General.....	15
Troubleshooting.....	15
Procedure for EM-35 Actuator Field Replacement	16
CHAPTER 6. VALVE SIZING—NON-DLE APPLICATIONS.....	19
Determination of Effective Area.....	19
Valve Sizing and the Effective Area Tables	20
Determining the Demand Required to Achieve Specific Flows.....	21
CHAPTER 7. MAINTENANCE	25
CHAPTER 8. SERVICE OPTIONS	26
Product Service Options.....	26
Woodward Factory Servicing Options	27
Returning Equipment for Repair	27
Replacement Parts	28
Engineering Services.....	28
How to Contact Woodward.....	29
Technical Assistance.....	29
3103/EM-35MR SPECIFICATIONS	30
REVISION HISTORY.....	31
DECLARATIONS.....	32

Illustrations and Tables

Figure 2-1. EM-35MR Actuator/3103 Gas Valve/Resolver Outline5
Figure 2-2. EM-35MR Actuator/3103 Gas Valve/Resolver Outline7
Figure 2-3. WAGO 264 Series Terminal Block.....11

Regulatory Compliance

These listings are limited only to those units bearing the CE Marking.

European Compliance for CE Marking:

Pressure Equipment Directive (Valve): Certified to Pressure Equipment Directive 97/23/EC of 29 May 1997 on the approximation of the laws of the Member States concerning pressure equipment, Category II. Moody International Certificate 90 174.

ATEX—Potentially Explosive Atmospheres Directive (Actuator, Resolver, Valve): Declared to 94/9/EEC COUNCIL DIRECTIVE of 23 March 1994 on the approximation of the laws of the Member States concerning equipment and protective systems intended for use in potentially explosive atmospheres.

LCIE 02 ATEX 6140 X Zone 1, Category 2, Group II G, EEx d IIB T3 X (Actuator)
 LCIE 02 ATEX 6141 X Zone 1, Category 2, Group II G, EEx d IIB T3 X (Resolver)
 Zone 1, Category 2, Group IIG c II X (3103 Valve)

IMPORTANT

EM-35/EM-35MR Actuator and 3103 Valve assemblies incorporating the minimum position switch are not suitable for use in an ATEX environment.

Other European Compliance:

Compliance with the following European Directives or standards does not qualify this product for application of the CE Marking:

EMC Directive: Compliance as a passive component to 89/336/EEC COUNCIL DIRECTIVE of 03 May 1989 on the approximation of the laws of the Member States relating to electromagnetic compatibility. Meets the surge requirements of EN 61000-6-2.

Machinery Directive: Compliance as a component with 98/37/EC COUNCIL DIRECTIVE of 23 July 1998 on the approximation of the laws of the Member States relating to machinery.

North American Compliance:

These listings are limited only to those units bearing the UL and/or CSA identification.

Suitability for use in North American Hazardous Locations is the result of compliance of the individual components:

Actuator: CSA Certified for Class I, Division 1, Groups C & D, Class I, Division 2, Groups B, C, and D, T3 at 149 °C Ambient. For use in Canada and the United States.

Minimum Position Switch: CSA Certified for Class I, Division 1, Groups C & D, Class II, Division 2, Groups E, F, and G. LR57324. UL Listed for Class I, Division 1, Groups C & D, Class II, Division 2, Groups E, F, and G. E14274.

Special Conditions for Safe Use

Wiring must be in accordance with North American Class I, Division 1 or 2 or European Zone 1 wiring methods as applicable, and in accordance with the authority having jurisdiction.

Ambient Temperature and Fuel Temperature:

(-40 to +149) °C / (-40 to +300) °F

Ambient Temperature and Fuel Temperature (Restriction for CE Marking):

(-29 to +149) °C / (-20 to +300) °F

Use supply wires suitable for a maximum ambient temperature of +149 °C.

For ATEX Zone 1 and Zone 2 Applications: A conduit seal must be installed within 50 mm (2 inches) of the conduit entries when the EM-35MR Actuator and EM Resolvers are used in a Zone 1 or a Zone 2 ATEX classified explosive atmosphere. These are Category 2, flameproof, type 'd' products.

For Class I, Division 1 or Class I, Zone 1 North American Applications: A conduit seal must be installed within 45 cm (18 inches) of the conduit entry when the EM-35MR Actuator or EM Resolvers are used in a Class I, Division 1 or Class I, Zone 1 hazardous atmosphere.

The surface of the gas valve is dependent upon the temperature of the fuel. Refer to the burn hazard warning statement below for safe handling. Fuel temperature effects on valve surface temperature must be taken into consideration when this product is used in an explosive atmosphere.

WARNING

EXPLOSION HAZARD—Do not connect or disconnect while circuit is live unless area is known to be non-hazardous.

Substitution of components may impair suitability for Class I, Division 1 or 2 or Zone 1 or 2 applications.

AVERTISSEMENT

RISQUE D'EXPLOSION—Ne pas raccorder ni débrancher tant que l'installation est sous tension, sauf en cas l'ambiance est décidément non dangereuse.

La substitution de composants peut rendre ce matériel inacceptable pour les emplacements de Classe I, applications Division 1 ou 2 ou Zone 1 ou 2.

CAUTION

The surface of this product can become hot enough or cold enough to be a hazard. Use protective gear for product handling in these circumstances. Temperature ratings are included in the specification section of this manual.

WARNING

GENERAL CONDITIONS FOR SAFE USE—Turbine control system alarms, faults, or shutdowns that are initiated by the valve or valve driver should not be ignored. These alarms, faults, and shutdowns are intended to alert equipment operators of a potentially unsafe condition and to protect against personal injury, loss of life, or property damage. Valve position error alarm and shutdown thresholds should be set to values that prevent improper fuel metering flow rates during turbine light-off. Equipment operators should strictly follow turbine OEM start procedures, including purging of the gas turbine after failed start attempts.

Electrostatic Discharge Awareness

All electronic equipment is static-sensitive, some components more than others. To protect these components from static damage, you must take special precautions to minimize or eliminate electrostatic discharges.

Follow these precautions when working with or near the control.

1. Before doing maintenance on the electronic control, discharge the static electricity on your body to ground by touching and holding a grounded metal object (pipes, cabinets, equipment, etc.).
2. Avoid the build-up of static electricity on your body by not wearing clothing made of synthetic materials. Wear cotton or cotton-blend materials as much as possible because these do not store static electric charges as much as synthetics.
3. Keep plastic, vinyl, and Styrofoam materials (such as plastic or Styrofoam cups, cup holders, cigarette packages, cellophane wrappers, vinyl books or folders, plastic bottles, and plastic ash trays) away from the control, the modules, and the work area as much as possible.
4. Do not remove the printed circuit board (PCB) from the control cabinet unless absolutely necessary. If you must remove the PCB from the control cabinet, follow these precautions:
 - Do not touch any part of the PCB except the edges.
 - Do not touch the electrical conductors, the connectors, or the components with conductive devices or with your hands.
 - When replacing a PCB, keep the new PCB in the plastic antistatic protective bag it comes in until you are ready to install it. Immediately after removing the old PCB from the control cabinet, place it in the antistatic protective bag.

NOTICE

To prevent damage to electronic components caused by improper handling, read and observe the precautions in Woodward manual 82715, *Guide for Handling and Protection of Electronic Controls, Printed Circuit Boards, and Modules*.

Chapter 1.

General Information

Introduction

The EM-35MR electric actuator is used to drive a 3103 gas valve, closed loop to position demand. Position feedback is provided by a resolver connected to the valve metering sleeve. Closed loop position control is accomplished through an EM 24 V Digital Driver. Having the feedback on the valve allows the motor assembly to be repaired or changed in the field without the loss of valve calibration.

3103 Gas Valve

The 3103 Gas Valve is a stainless steel valve capable of metering gas flow between 23 kg/h and 18 144 kg/h (50 lb/h and 40 000 lb/h). The valve is designed to bolt into a 50 mm (2 inch) line by means of 0.625-11 UNC 2B tapped holes. The flange is class 600 per ANSI B16.5. The valve design is a rotary metering sleeve and a shoe-type throttling valve. The valve shoe is spring- and pressure-loaded against the metering port to minimize leakage and to self-clean the metering port. Metering port area is determined by input shaft positioning from the actuator. The valve has an internal spring to return the valve to the minimum fuel position in the event of a power loss to the actuator.

The 3103 valve has redundant seals on all dynamic sealing surfaces. Between these two seals is an overboard vent which vents any gasses that may leak past the first seal to safe vent location. The use of an inner-seal vent prevents the second dynamic seal from seeing any differential pressure and thus offers protection against the leakage of gasses from the valve into the surrounding ambient atmosphere.

The valve design incorporates an inlet guide tube to condition the inlet flow and to direct any gas contaminants through the metering port, minimizing any accumulation in the valve housing. The metering sleeve support bearings are positively sealed from the gas. Internal valve parts are made of through-hardened stainless steel.

NOTICE

The valve has mechanical stop screws installed in the valve flange. These stops must not be adjusted by the customer. If these stops interfere with the valve operating region or the electrical stops, it will cause the EM 24 V Digital Driver to trip out on overcurrent.

NOTICE

The customer installation should provide proper fuel filtration and adequate heating to prevent fuel saturation, constituent precipitation, and/or hydrate formation on the valve wetted parts. Performance degradation or valve failure may result.

NOTICE

The customer should take into account gas constituents that may cause adverse material compatibility issues.

NOTICE

The customer should prevent installation debris from remaining on, around, or within the valve housing or actuator junction box. Electrical shorting or contamination of the product may result.

EM-35MR Actuator

The EM-35MR actuator is an all-electric actuator designed for use in industrial gas turbine control applications. The EM-35MR actuator consists of a high performance brushless servomotor and a precision planetary gearbox with two resolver-type shaft position sensors. All stator windings are completely sealed. The use of a high efficiency gearbox facilitates high servo system bandwidth. The motor has its own resolver providing motor rotor position feedback, and the other resolver(s) provides accurate output shaft position feedback. The actuator also has a slip clutch to allow full speed impact into optional external rigid mechanical stops.

The motor assembly is housed in a cast aluminum explosion proof housing. A thermal potting compound is used to transfer waste heat generated by the motor, to the cast, explosion-proof housing and out to the ambient environment. Wiring to the motor is accomplished through two .750-14 NPT conduit connections or two M25 x 1.5 conduit connections into a wiring compartment integral to the housing. One conduit is for the motor power wires, the other is for the motor resolver wires. The motor output shaft is directly coupled to the valve input shaft through the use of a stainless steel torsional coupling.

Resolver

Position feedback is accomplished using a highly accurate brushless resolver(s). The resolver is directly coupled to the valve metering shaft through use of a stainless steel bellows and is housed in an explosion proof enclosure. The resolver receives its excitation from the EM driver. The EM driver uses a resolver-to-digital converter to determine valve position using the output voltages from the resolver's two secondary windings. Resolver accuracy is $\pm 0.05^\circ$. Wiring to the resolver is accomplished through two .750-14 NPT conduit connections or two M25 x 1.5 conduit connections.

Applications

The 3103/EM-35MR is well suited for metering flow to a gas turbine that is in continuous operation. When used in applications where the turbine is frequently in a standby mode, power should be removed from the valve, or it should be placed in a slow cycle relubrication mode. Either of these procedures will prevent accelerated wear on the actuator. See Woodward application note 51424 for additional information and/or contact Woodward for details on how to implement these procedures.

Chapter 2. Installation

Unpacking

Be careful when unpacking the EM 24 V Digital Driver and EM-35MR actuator/3103 gas valve. Check the devices for signs of damage such as bent or dented case and loose or broken parts. If damage is found, notify the shipper immediately. The devices may be stored in their original shipping containers until they are ready for installation. Protect the devices from weather and from extreme humidity or temperature fluctuations during storage.

WARNING

External fire protection is not provided in the scope of this product. It is the responsibility of the user to satisfy any applicable requirements for their system.

CAUTION

The 3103/EM-35MR assembly weight is approximately 44 kg (96 lb). In order to prevent injury, a lifting strap or other means of lifting assistance should be used when handling this product.

CAUTION

Due to typical noise levels in turbine environments, hearing protection should be worn when working on or around the 3103 Gas Valve.

CAUTION

The surface of this product can become hot enough or cold enough to be a hazard. Use protective gear for product handling in these circumstances. Temperature ratings are included in the specification section of this manual.

Power Requirements

The EM-35MR actuator receives all of its power from the EM driver. The full actuator operating range of the actuator is (18 to 32) V (dc). The maximum steady state driver input current is 15 A continuous with peaks of 37 A for 50 ms.

WARNING

EXPLOSION HAZARD—For Zone 1 / Division 1 products: Proper torque is very important to ensure that the unit is sealed properly.

Actuator cover bolt torque is:

0.250-28 socket head cap screw = 9.2 N·m (81 lb-in)

M6 x 1 socket head cap screw = 8.0 N·m (71 lb-in)

Resolver cover bolt torque is 9.2 N·m (81 lb-in).

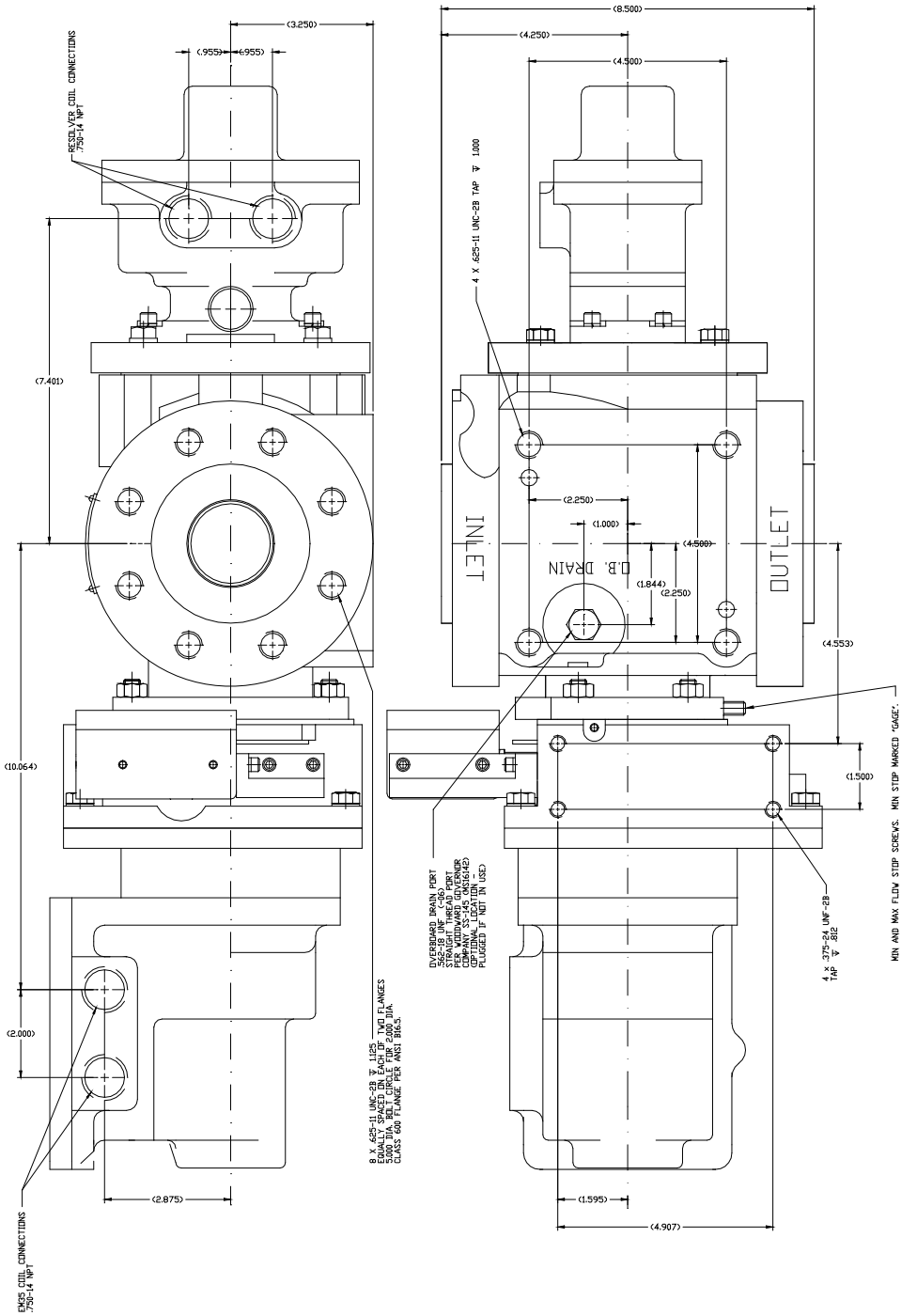

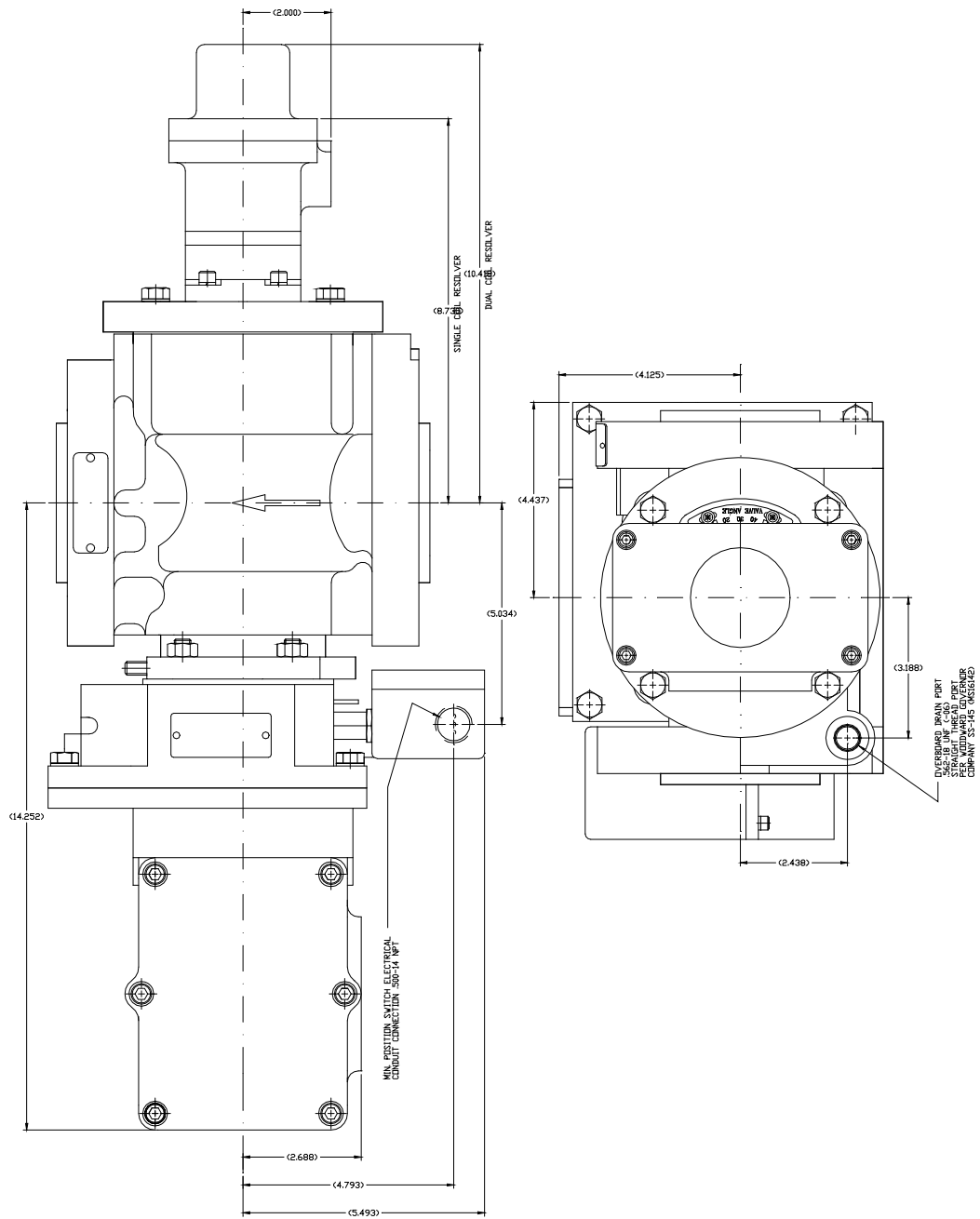
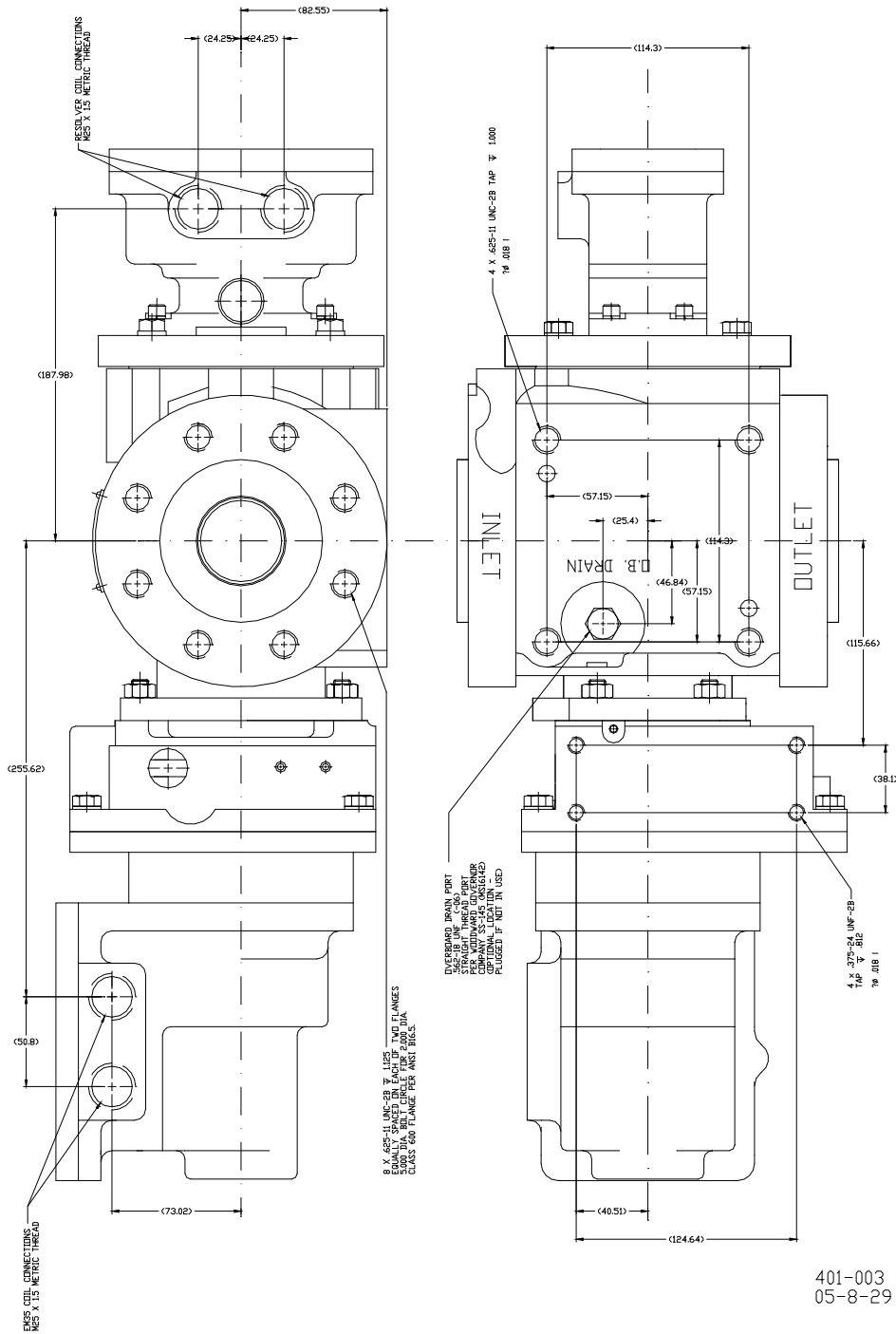

Figure 2-1. EM-35MR Actuator/3103 Gas Valve/Resolver Outline (NPT electrical conduit entries)



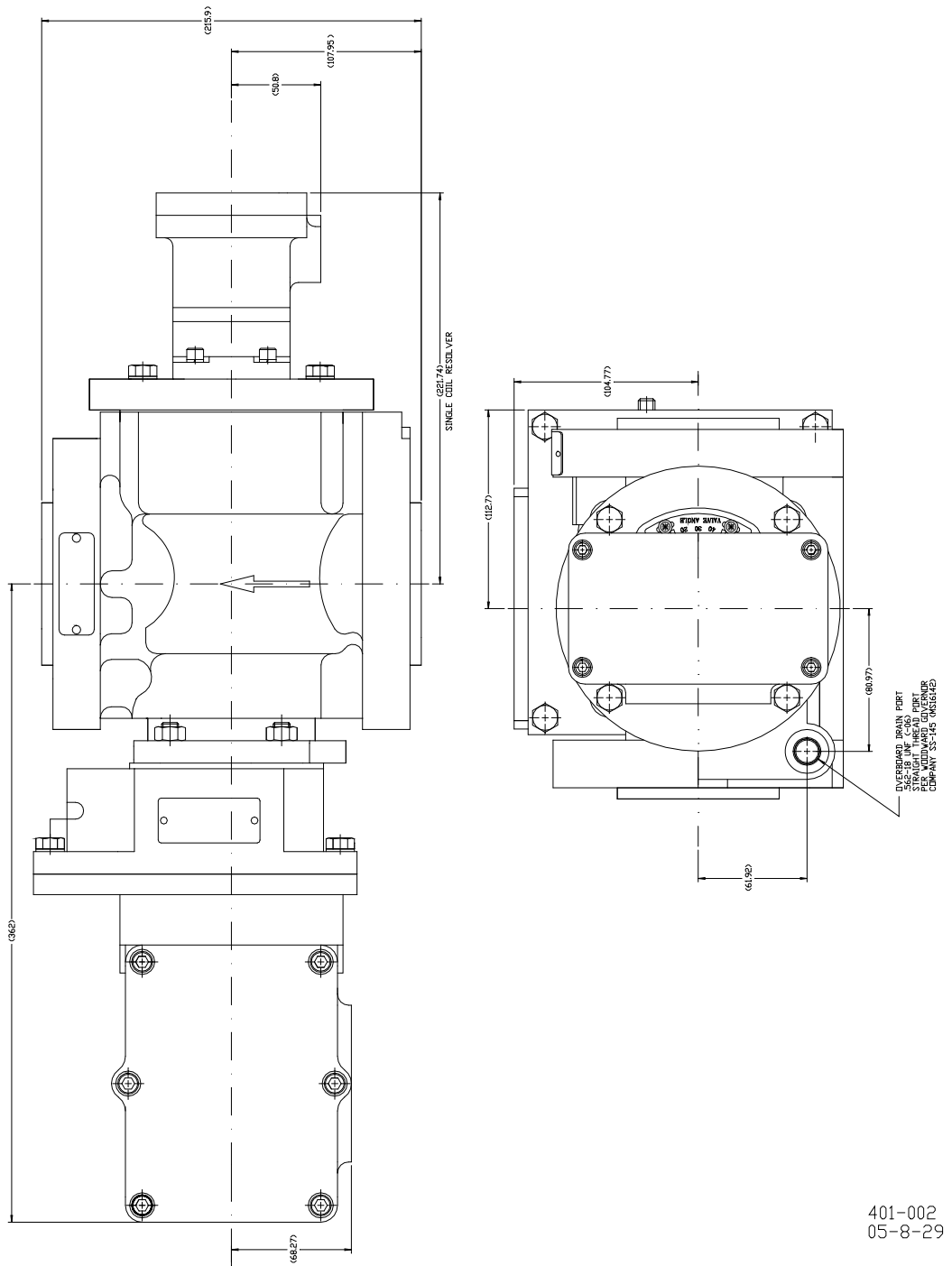

Figure 2-2. EM-35MR Actuator/3103 Gas Valve/Resolver Outline (metric electrical conduit entries)

401-002
05-8-29

EM Actuator/3103 Gas Valve Installation

For most applications, the valve/actuator assembly can be supported by the 50 mm (2 inch) flanges when bolted into the system piping. For applications where this is not practical or where additional support is required, the assembly can be bolted to a supporting structure by the four 0.625-11 UNC-2B tapped holes in the valve base.

See Figures 2-1 and 2-2 for overall dimensions, installation hole locations, and any fitting or plumbing connections. Installation attitude does not affect valve/actuator performance.

Make sure that adequate room is allowed for required wiring and that the wiring and valve/actuator are accessible for service.

There are two overboard drains on the 3103 valve (see Figures 2-1 and 2-2). One is to be plumbed to an area outside the turbine enclosure. Use the overboard drain most convenient for your installation and plug the one that is not used. This drain vents the cavities between the inner and outer seals on both ends of the valve shaft.

WARNING

EXPLOSION HAZARD—The overboard drain port vents process fuel to the atmosphere. The overboard drain gas volume may increase as temperatures drop below 0 °C (32 °F). Plan the vent system, taking temperature affects into consideration. Vent the drain ports to a safe location away from the turbine enclosure or any hazardous location / explosive atmosphere. Protect the vent line from obstruction, physical damage, condensation, or corrosion.

NOTICE

Maximum overboard vent pressure is 69 kPa (10 psig). Exceeding this pressure can potentially damage the valve.

NOTICE

DO NOT plug both drains. This can cause pressure to build up in the vent cavity and potentially damage the valve.

IMPORTANT

It is recommended that the end of the line (outside the enclosure) be placed in a small container of clean, lightweight oil to check for gas leakage. This will also prevent a corrosive or salt air atmosphere from corroding the shaft bearings which are in the cavity between the shaft seals.

Piping Installation

Refer to ASME B16.5 for details of flange, gasket, and bolt types and dimensions.

The gas fuel control valve is designed for support by the piping flanges alone; additional supports are neither needed nor recommended.

Verify that the process piping centerline-to-flange-face dimensions meet the requirements of the outline drawings (Figures 2-1 and 2-2) within standard piping tolerances. The valve should mount between the piping interfaces such that the flange bolts can be installed with only manual pressure applied to align the flanges. Mechanical devices such as hydraulic or mechanical jacks, pulleys, chain-falls, or similar should never be used to force the piping system to align with the valve flanges.

ASTM/ASME SA-449 grade or better bolts or studs should be used to install the valve into the process piping. The bolt length and diameter for Class 600 flanges shall conform to the following table.

Nominal Pipe Size	Number of Bolts	Diameter of Bolts	Stud Length	Machine Bolt Length
51 mm / 2 inch	8	16 mm / 5/8 inch	108.0 mm / 4.25 inch	88.9 mm / 3.50 inch

Flange gasket materials should conform to ASME B16.20. The user should select a gasket material which will withstand the expected bolt loading without injurious crushing, and which is suitable for the service conditions.

When installing the valve into the process piping, it is important to properly torque the stud/bolts in the appropriate sequence in order to keep the flanges of the mating hardware parallel to each other. A two-step torque method is recommended. Once the studs/bolts are hand tightened, torque the studs/bolts in a crossing pattern to half the required torque. Once all studs/bolts have been torqued to half the appropriate value, repeat the pattern until the rated torque value is obtained.

Electrical Connections

WARNING

Improper grounding of the product can result in electric shock or electrocution. Installation of a protective earth ground at the provided terminal lugs on the valve is required for safe installation.

NOTICE

Wire and cable installation of the product should take into account proper cable support or strain relief to prevent stress on the cable or internal wire connections at the terminals.

Shielded Wiring

1. All shielded cable must be twisted conductor pairs with either a foil or a braided shield.
2. All signal lines should be shielded to prevent picking up stray signals from adjacent equipment.
3. Connect the shields as shown in the plant wiring diagram in EM Driver manual 26159. Wire exposed beyond the shield must not exceed two inches. The other end of the shield must be left open and insulated from any other conductor.
4. Do not run shielded signal wires with other wires carrying large currents.
5. See application note 50532, *EMI Control in Electronic Governing Systems*, for more information.

Installations with severe electromagnetic interference (EMI) may require shielded cable run in conduit, double shielded wire, or other precautions. Contact Woodward for more information.

WARNING

EXPLOSION HAZARD—Do not connect or disconnect while circuit is live unless area is known to be non-hazardous.

Substitution of components may impair suitability for Class I, Division or Zone applications.

WARNING

Explosion Proof / Flame Proof Covers. Take care not to damage the cover seal, the cover surface, the threads, or the actuator or resolver surface while removing or replacing the cover.

WARNING

EXPLOSION HAZARD—For Zone 1 / Division 1 products: Proper torque is very important to ensure that the unit is sealed properly. Actuator cover bolt torque is:
 0.250-28 socket head cap screw = 9.2 N·m (81 lb-in)
 M6 x 1 socket head cap screw = 8.0 N·m (71 lb-in)
 Resolver cover bolt torque is 9.2 N·m (81 lb-in).

IMPORTANT

The EM-35MR Actuator and EM Resolvers are certified as type 'd' (flameproof enclosure) ATEX Category 2 equipment, suitable for use in a Zone 1 explosive atmosphere. Wiring methods must comply with this Zone 1-Category 2 method of protection when installed in either a Zone 1 or a Zone 2 classified atmosphere. Conduit seals are required. Refer to the Special Conditions for Safe Use stated on page iii.

Plant Wiring

WARNING

Due to the hazardous location listings associated with this product, proper wire type and wiring practices are critical to operation.

NOTICE

Do not connect any cable grounds to “instrument ground”, “control ground”, or any non-earth ground system.

Consult the EM Driver manual (26159) for plant wiring diagram, and for specific wiring requirements and procedures.

1. Power wiring between the motor and the driver: Any extra motor wire in the installation should be cut off and discarded, not coiled.

IMPORTANT

Coiled wire will cause an inductance that could be greater than that of the motor.

2. The metering valve is not shipped with any field wiring attached (such as pigtails) but rather is provided with internal terminal blocks for field wiring. These terminal blocks are located under the explosion proof covers on the actuator and resolver housings.

3. The non-metric actuator housing has two 0.75 inch NPT taps and the resolver housing has two .750-14 NPT taps. The metric actuator housing has two M25 x 1.5 taps and the resolver housing has two M25 x 1.5 taps.
4. The resolver wires need to be run through the wiring connection in front of the 10 pole WAGO® terminal block. The actuator power wires should go through the other wiring connection.

The terminal blocks provided for the motor resolver wires and the position resolver are WAGO 264 series. These terminal blocks are top load terminal blocks and are actuated by inserting a DIN 5264 screwdriver into the opening behind the wire slot. Once the cage clamp has been opened, the wire can be inserted and the screwdriver removed. Please see the illustration and instructions below.

The screwdriver is inserted into the operating slot up to the stop.

1. Insert the screwdriver into the operating slot up to the stop.
2. Use the screwdriver blade to hold the clamping spring open so that the conductor can be introduced into the clamping unit.
3. Withdraw the screwdriver. The conductor is automatically clamped.

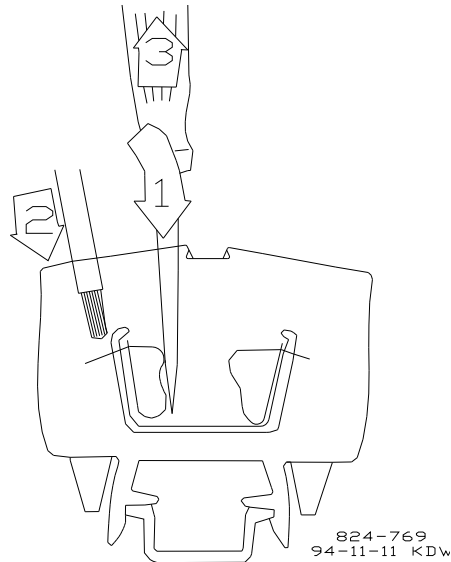

Figure 2-3. WAGO 264 Series Terminal Block

Chapter 3.

Description of Operation

EM-35MR Actuator

The EM-35MR electric actuator is comprised of a brushless dc motor, a clutch assembly, a gearhead assembly, and an explosion proof housing. The brushless dc motor uses Samarium Cobalt permanent magnets bonded and sleeved to the rotor. The high speed motor output shaft is clutched before the gearbox assembly. This clutch prevents damage to the motor shaft and gearbox should an external force suddenly stop the rotation of the gearbox output shaft. The clutch slips at 1.5 times the maximum output force of the motor/gearbox assembly. The motor gearbox is a planetary gearbox and is used to reduce the output speed and increase the output torque.

The control signals for the motor come from an external motor driver. The motor driver handles motor commutation as well as closed loop position control. The position feedback comes from a precision resolver directly coupled to the valve metering sleeve. This arrangement prevents any errors in sensing the desired valve position through linkages and gear trains and results in precise position control. Having the feedback on the valve also allows for the motor to be repaired or replaced in the field without any loss of calibration.

The entire motor assembly is installed in a cast explosion proof housing. The motor is heat sunk to this external housing to allow heat generated by the motor to be effectively transferred to the ambient environment.

The output shaft of the gear train is supported by two roller bearings. To minimize side load to the motor the output shaft is directly coupled to the valve using a stainless steel torsional coupling. The torsional coupling efficiently transmits the motor torque to the valve with very little lost motion and is key to achieving the desired position control of the valve.

3103 Gas Valve

Actuator output shaft movement positions the gas valve metering sleeve and resolver. Gas flow is metered at the valve through a ported rotary sleeve. Gas enters the inlet port (P1) where it is directed through the inlet guide tube to the rotary metering port. A spring and pressure loaded, sharp edged shoe seals against the metering sleeve. Metered fuel is discharged at the outlet pressure. Metered fuel is determined by valve position, inlet pressure (P1), outlet pressure (P2), gas temperature, and gas composition.

Chapter 4. Actuator/Valve Calibration

EM-35MR Actuator/3103 Gas Valve with Driver

For calibration details, see the Dry Low Emissions, Fuel Metering Valves: Warnings, Calibration, and Installation manual (40142). For non-DLE systems see the EM 24 V Digital Driver manual (26159).

The EM-35MR actuator/gas valves used with the digital driver is typically for applications that require extremely high accuracy, like dry low emissions (DLE) control. For that reason, all calibration of the actuator/valve assembly is performed at the factory.

The mechanical stops on the valve limit valve travel and prevent damage to the valve caused by driving it beyond its normal range. Flow calibration is achieved using the digital resolver feedback and a valve characterization table. The flow vs. angle data is determined for each valve during the flow testing and is recorded on a floppy disk.

No field rigging is required to calibrate the valve. There is a warning tag on the valve and a warning message on the operator panel stating that the table identification (serial number and date code) must match the valve identification.

For non-DLE applications, Woodward offers a series of standard 3103/EM-35MR valves. From the factory, these valves have the minimum and maximum stops set outside the normal operating window of 0 to 60 degrees valve travel, and the flow calibration schedule is not for a specific application. To determine the minimum and maximum flow valve positions, and any intermediate open loop flow schedule points, follow the steps in Chapter 6: Valve Sizing.

WARNING

Significant turbine damage, high emissions levels, release of high temperature gas, fire, damage to nearby equipment, injury to personnel, or death may result from incorrect fuel valve calibration.

To correctly operate the fuel metering valve(s), the MicroNet™ or NetCon® controller must be programmed with the correct valve characterization curve for the specific valve being used. Woodward provides the programming information to the valve purchaser in the form of a data file specifically identified by the valve serial number and date. The supplier of the application program must incorporate the valve characterization data file into the application program by following the procedure described in this manual.

Failure to follow the procedure herein, or any non-Woodward alteration (including attempt to repair), or damage to the valve, may result in a change of characteristics leading to the same potential hazards.

WARNING

Be prepared to make an emergency shutdown when starting the engine, turbine, or other type of prime mover, to protect against runaway or overspeed with possible personal injury, loss of life, or property damage.

! WARNING

EXPLOSION HAZARD—Improper valve positioning may cause excessive fuel delivery to the engine, resulting in an explosion. Carefully check the following warnings:

- (1) Proper configuration of the resolver offset is required for the valve to be calibrated correctly and for the valve to position correctly. Every valve has a different position offset number. These values must be entered into the valve driver prior to engine operation.
- (2) Proper configuration of the backup demand tracking error, position error, and resolver feedback error settings are critical for the valve driver to correctly identify differences in position demand. These values must be entered into the valve driver prior to engine operation. The use of the driver defaults is recommended.
- (3) It is recommended to set the valve to “Drive to Minimum” position for the shutdown configuration to reduce the risk of over-fuel of the engine when a shutdown is issued.
- (4) 3103 valve calibration files (*.vlv) should not be edited. Editing these files can create an unstable operational mode and may result in erratic behavior or excessive fuel delivery to the engine.
- (5) 3103 valve calibration files (*.vlv) loaded into the turbine control should be verified to match the serial number of the valve they are intended to control. Failure to verify that the serial number matches may result in excessive fuel delivery to the engine.
- (6) The turbine control analog demand to the driver should be calibrated to verify that the proper 4 mA to 20 mA signal is provided. Failure to do so may result in excessive fuel delivery to the engine.
- (7) After any field service to the valve, a verification of the valve minimum stop reading to the valve test report (TSP) should be performed. A shift in the valve resolver may cause excessive fuel delivery to the engine.

Chapter 5.

Troubleshooting and Field Replacement

General

Faults in the governing system are usually revealed as speed variations of the prime mover, but it does not necessarily follow that such speed variations indicate governing system faults. Therefore, when improper speed variations appear, check all components including the prime mover for proper operation.

Problems with the 3103/EM-35MR assembly will usually show up as faults in the driver. Refer to the appropriate EM 24 V Driver manual (26159) for detailed fault information.

Overcurrent trips experienced by the driver can be caused by driving the valve into (or operating too close to) the mechanical stops. These stop screws are used for calibration purposes only and are backed out of the valve operating range before shipment to the customer.

Troubleshooting

Problem	Symptom	Solution
Erratic or Unstable Operation	Uncontrollable or unstable valve operation.	Electromagnetic interference may be causing noise on feedback signal to driver or no driver demand signal. Refer to the Woodward wiring best practices manual 51204 for installation guides.
		Feedback resolver signals may be swapped.
		Motor wire may be contacting intermittently or is loose. Check motor wire terminals for loose connections.
	Valve will not enter run mode when reset.	Motor phase connections may be swapped. Check motor wiring. If one phase is swapped, the motor will try to operate in reverse, causing it to drive into the minimum stop.
	No fault signals present, but valve will not operate.	Feedback resolver signals may be connected but are swapped. Check Sin and Cos terminal connections. Driver diagnostics may register that a proper connection is made, but the connections may be on the wrong terminals.
Inaccurate Fuel Delivery.	The fuel gas accuracy is critical for accurate fuel metering. Verify that the gas Lower Heating Value (LHV), Specific Gravity (Sg), Ratio of Specific Heats (k), Compressibility (z), fuel temperature, and fuel pressure are all correct.	
	Verify resolver offset is input correctly.	
	DLE Valves—Verify the valve calibration (*.vlv) file is entered into the control, and the correction table serial number matches the valve serial number.	
Position Error (Shutdown Position)	During run time, the valve will check if the position feedback and the demanded position are the same. If not, a position error will be flagged, and the valve will be shut down.	Check if there is an obstruction in the valve. Check if the valve metering elements need to be cleaned. Check pressure ratings.
		Check to see if the motor makes a “grinding” noise when actuated.
		Check for water damage inside the actuator junction box.

Procedure for EM-35 Actuator Field Replacement

The EM-35 actuator may be replaced in the field without affecting the calibration of the valve/actuator assembly. This procedure describes the steps necessary to perform an actuator replacement in the field.

Required Tools: 3/16" ball hex driver, 6" long, 3/8" drive
 5/16" ball hex driver, 6" long, 3/8" drive
 3/8" drive ratchet
 5/16" hex Allen wrench
 3/8" drive torque wrench, capable of 33.2 N·m (24.5 lb-ft)

Procedure

1. Locate the coupling assembly between the 3103 gas valve and the EM-35 actuator; it can be viewed through the long vertical slot in the adapter housing.

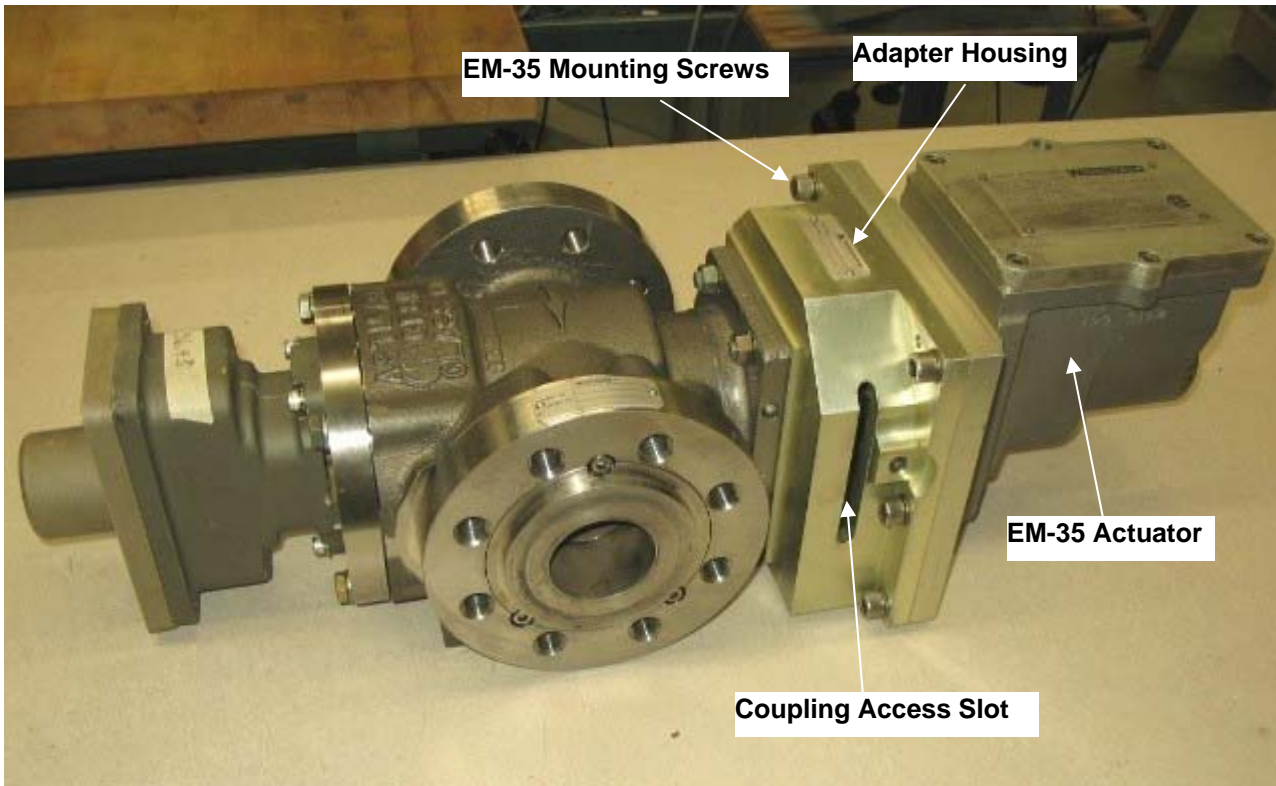

- Using the 3/16" ball hex driver, loosen the socket head cap screw that clamps the coupling assembly to the EM-35 output shaft. Do not loosen the clamp screw that mounts the coupling assembly to the valve shaft.



- Using the 5/16" Allen wrench, remove the five socket head cap screws and lock washers that mount the EM-35 actuator to the adapter housing. Remove the EM-35 actuator from the assembly.



4. Before installing the new EM-35 actuator, properly orient the unit so the two lining pins for the actuator match up with the corresponding holes in the adapter housing. If necessary, rotate the shaft of the EM-35 motor by hand to properly orient the splines up with those of the coupling assembly.

When everything is in position, first slip the actuator shaft into the coupling assembly, then line up the pins of the actuator with the adjacent holes in the adapter housing. The actuator should mate up without any binding or use of significant force.

5. Once the actuator is in proper position, re-install the five socket head cap screws and lock washers removed in step 3. Torque the bolts to 33.2 N·m (24.5 lb-ft).
6. Using the 3/16" long ball hex driver and torque wrench, tighten the socket head cap screw on the coupling at the EM-35 output shaft. Torque to 9.3 N·m (82 lb-in).
7. Reconnect field wiring to EM-35 actuator terminal blocks.
8. Perform valve stroking procedure, verifying the valve can be stroked from the minimum to maximum stop.

Chapter 6.

Valve Sizing—Non-DLE Applications

Determination of Effective Area

In order to choose the proper size of valve for an application, the *effective area* required to meet your maximum flow requirement must first be determined. The effective area is determined using the following equations.

$$R7(K) = \left(\frac{2}{1+K} \right)^{\frac{K}{K-1}}$$

$$\text{If } \frac{P2}{P1} \geq R7 \quad \text{Effective_Area} = \frac{\text{FLOW}}{\left[3955.289 \cdot P1 \cdot \sqrt{\left[\frac{K \cdot Sg}{(K-1) \cdot T \cdot Z} \right] \cdot \left[\left(\frac{P2}{P1} \right)^{\frac{2}{K}} - \left(\frac{P2}{P1} \right)^{\frac{1+K}{K}} \right]} \right]}$$

$$\text{If } \frac{P2}{P1} < R7 \quad \text{Effective_Area} = \frac{\text{FLOW}}{\left[3955.289 \cdot P1 \cdot \sqrt{\left[\frac{K \cdot Sg}{(K-1) \cdot T \cdot Z} \right] \cdot \left(R7^{\frac{2}{K}} - R7^{\frac{1+K}{K}} \right)} \right]}$$

Where:

- P1 = Valve inlet pressure (psia)
- P2 = Valve discharge pressure (psia)
- K = Ratio of specific heats for the gas (1.300 typical for standard natural gas at 60 °F)
- Sg = Specific gravity relative to air for the gas (0.60 typical for standard natural gas)
- Flow = Valve metered flow (lb/h)
- T = Temperature of the gas (Deg Rankine) (Deg R = Deg F + 459.7)
- Z = Gas Compressibility Factor (essentially 1 for most applications—see the following graph)

IMPORTANT

The valve size selected should be sized to be adequate for worst-case flow conditions. This would be minimum P1, maximum P2, maximum flow, and maximum temperature.

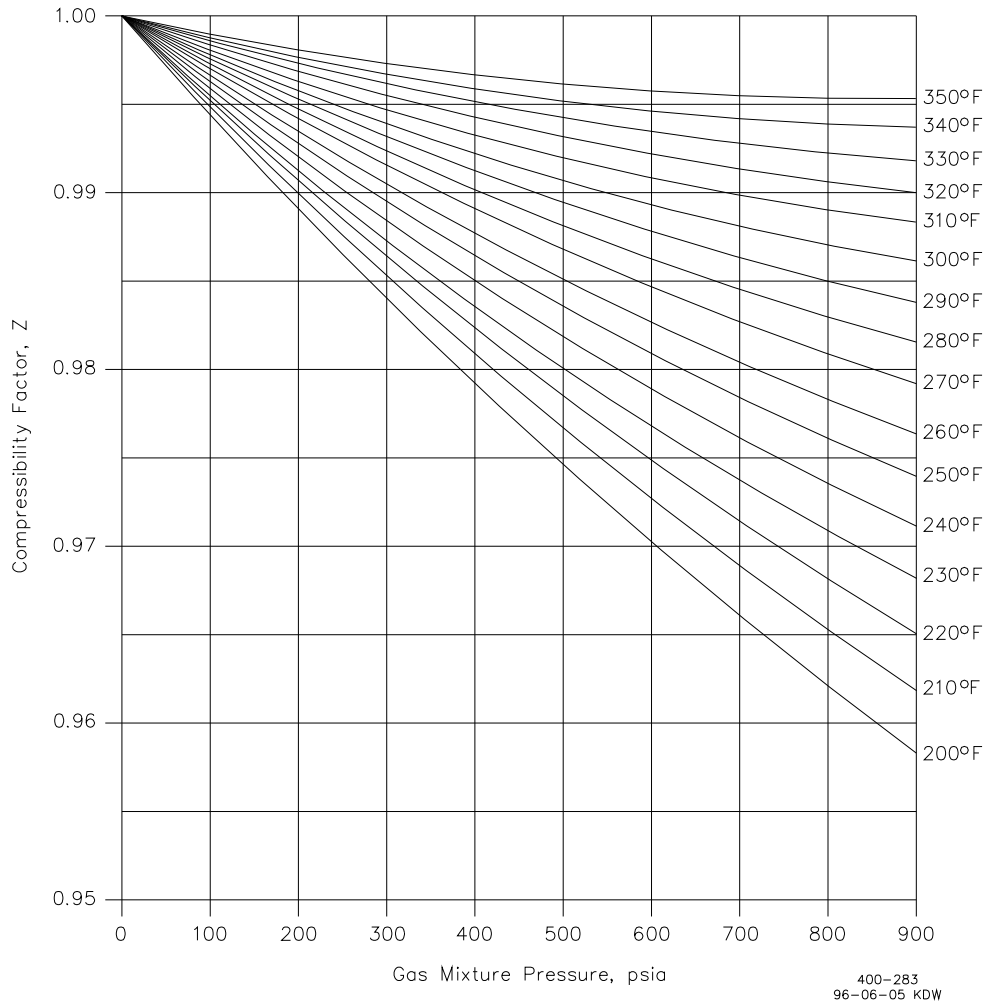

Valve Sizing and the Effective Area Tables

Once the effective area has been determined, move to the effective area tables later in this chapter. The effective area table has % valve travel, demand mA, and valve angle listed in the first three columns. The following ten columns list the valve effective area for pressure ratios (P_2/P_1) from 0.05 to 0.95 respectively. To pick the proper size valve for an application, move to the sheet that has a value for effective area greater than or equal to that determined above in the 100 % travel row for the applicable pressure ratio column.

IMPORTANT

Woodward recommends that no less than 60 % valve travel be used for the full control range. Using less than that could cause instability problems as the system attempts to control at very low increments of travel.

Determining the Demand Required to Achieve Specific Flows

To determine demand values necessary to achieve a specific flow at end or intermediate points once the valve size is set, is very similar to the process used for sizing the valve. First, determine the necessary valve effective area for the flow point. Interpolate between pressure ratios and demand columns to determine at what percent/mA/valve angle the flow will be achieved.

Notes on the Valve Sizing and Application Program

The algorithm used for sizing and demand value determination used in the standard valve application programs available for the 3103 is basically the same as that described above. However, the program makes use of a valve inlet pressure compensation algorithm that enhances the accuracy of the calculation. This compensation scheme is not easily implemented in a manual system as described here. Therefore, the demand values determined using the methods described here will be slightly different from those determined using the application programs. Since this difference is small, the use of the application program is not absolutely necessary for the sizing/application of standard valves.

3103 1.0 in² port, Effective Area Table

% travel	Driver mA	Valve Angle	Pressure Ratio (P2/P1)												
			0.05	0.15	0.25	0.35	0.45	0.55	0.65	0.75	0.85	0.95			
1.67	4.27	1	0.002337	0.0022	0.001808	0.001526	0.00126	0.00106	0.000861	0.000762	0.000682	0.000517			
5.00	4.80	3	0.004383	0.004201	0.004071	0.00392	0.003454	0.003164	0.002957	0.002796	0.002643	0.002517			
8.33	5.33	5	0.008714	0.008391	0.008139	0.007884	0.007565	0.007204	0.006857	0.006528	0.006314	0.006048			
11.67	5.87	7	0.014965	0.014686	0.014411	0.014062	0.01372	0.013244	0.012773	0.012285	0.012016	0.011676			
15.00	6.40	9	0.023371	0.023129	0.022911	0.022525	0.022114	0.021357	0.020707	0.020176	0.019709	0.019213			
18.33	6.93	11	0.033982	0.033704	0.033444	0.033075	0.032501	0.031429	0.030431	0.029712	0.029038	0.028567			
21.67	7.47	13	0.045984	0.045694	0.045473	0.045127	0.044673	0.043643	0.042342	0.041372	0.040536	0.039672			
25.00	8.00	15	0.06132	0.060776	0.06042	0.060059	0.058889	0.056745	0.054926	0.05317	0.052747	0.051417			
28.33	8.53	17	0.076908	0.076908	0.076578	0.075679	0.074694	0.07185	0.069344	0.067442	0.06807	0.065109			
31.67	9.07	19	0.095228	0.095228	0.095258	0.094578	0.092506	0.089693	0.086327	0.084197	0.0832	0.080651			
35.00	9.60	21	0.116967	0.116967	0.116604	0.115514	0.113071	0.109084	0.10513	0.102132	0.100802	0.096763			
38.33	10.13	23	0.139902	0.139902	0.139321	0.138721	0.135686	0.130507	0.125658	0.121907	0.120916	0.116644			
41.67	10.67	25	0.165077	0.165077	0.164679	0.16383	0.160401	0.154103	0.148472	0.144755	0.141415	0.138006			
45.00	11.20	27	0.193022	0.193022	0.192068	0.190605	0.187127	0.179773	0.173156	0.168142	0.166079	0.161671			
48.33	11.73	29	0.222766	0.222766	0.221606	0.2198	0.215081	0.206895	0.199404	0.195174	0.19161	0.186544			
51.67	12.27	31	0.253217	0.253217	0.253217	0.251683	0.246095	0.23748	0.228845	0.223055	0.219556	0.214734			
55.00	12.80	33	0.287995	0.287995	0.287995	0.285949	0.279469	0.268687	0.259894	0.254099	0.249593	0.244918			
58.33	13.33	35	0.32387	0.32387	0.32387	0.321422	0.314429	0.302898	0.293191	0.286769	0.281981	0.277058			
61.67	13.87	37	0.362255	0.362255	0.362255	0.359608	0.352007	0.339526	0.330097	0.322144	0.317	0.311874			
65.00	14.40	39	0.399695	0.399695	0.399695	0.396695	0.390906	0.37772	0.367555	0.359668	0.354956	0.350258			
68.33	14.93	41	0.441035	0.441035	0.441035	0.441035	0.43291	0.417849	0.40695	0.400306	0.395567	0.390794			
71.67	15.47	43	0.48585	0.48585	0.48585	0.48585	0.476249	0.461373	0.450513	0.441353	0.438702	0.433496			
75.00	16.00	45	0.527719	0.527719	0.527719	0.527719	0.51943	0.506218	0.49475	0.48265	0.485295	0.481632			
78.33	16.53	47	0.56635	0.56635	0.56635	0.56635	0.56635	0.55306	0.541886	0.533155	0.534196	0.530191			
81.67	17.07	49	0.62072	0.62072	0.62072	0.62072	0.62072	0.603415	0.588903	0.587288	0.587494	0.58495			
85.00	17.60	51	0.670282	0.670282	0.670282	0.670282	0.670282	0.652262	0.641498	0.642622	0.644286	0.64309			
88.33	18.13	53	0.712481	0.712481	0.712481	0.712481	0.712481	0.712481	0.702241	0.698165	0.704086	0.707164			
91.67	18.67	55	0.760268	0.760268	0.760268	0.760268	0.760268	0.760268	0.760268	0.760268	0.765023	0.77641			
95.00	19.20	57	0.820973	0.820973	0.820973	0.820973	0.820973	0.820973	0.820973	0.820973	0.837028	0.850793			
98.33	19.73	59	0.92862	0.92862	0.92862	0.92862	0.92862	0.92862	0.92862	0.92862	0.92862	0.92862			

Valve angle = Resolver Feedback Angle – Resolve Offset Angle
 Resolver Offset Angle = ~20 degrees
 4 mA = 0° valve angle = 0 % valve position = ~20 resolver angle
 min stop = -2 degrees valve angle
 max stop = 62 degrees valve angle

3103 1.5 in² port, Effective Area Table

% travel	Driver mA	Valve Angle	Pressure Ratio (P2/P1)																		
			0.05	0.15	0.25	0.35	0.45	0.55	0.65	0.75	0.85	0.95									
1.67	4.27	1	0.003733	0.003733	0.003404	0.003029	0.002621	0.002372	0.002078	0.001843	0.001646	0.001466	0.001286	0.001111	0.000941	0.000776	0.000616	0.000461	0.000311	0.000161	
5.00	4.80	3	0.006658	0.006658	0.006313	0.005853	0.005576	0.005038	0.004714	0.004428	0.004153	0.003887	0.003630	0.003373	0.003116	0.002859	0.002602	0.002345	0.002088	0.001831	0.001574
8.33	5.33	5	0.009595	0.009595	0.009271	0.008825	0.008499	0.007942	0.007526	0.007101	0.006685	0.006269	0.005853	0.005437	0.005021	0.004605	0.004189	0.003773	0.003357	0.002941	0.002525
11.67	5.87	7	0.01937	0.01937	0.019018	0.018666	0.017997	0.017168	0.016424	0.015901	0.015443	0.014985	0.014527	0.014069	0.013611	0.013153	0.012695	0.012237	0.011779	0.011321	0.010863
15.00	6.40	9	0.032537	0.032537	0.032199	0.031719	0.030975	0.029645	0.028811	0.027876	0.027126	0.026376	0.025626	0.024876	0.024126	0.023376	0.022626	0.021876	0.021126	0.020376	0.019626
18.33	6.93	11	0.050748	0.050748	0.050453	0.049786	0.048368	0.046005	0.044153	0.042741	0.041329	0.039917	0.038505	0.037093	0.035681	0.034269	0.032857	0.031445	0.030033	0.028621	0.027209
21.67	7.47	13	0.071066	0.071066	0.070615	0.069425	0.068783	0.066366	0.063605	0.061651	0.059941	0.058231	0.056521	0.054811	0.053101	0.051391	0.049681	0.047971	0.046261	0.044551	0.042841
25.00	8.00	15	0.09497	0.09497	0.094513	0.094139	0.092182	0.089092	0.085522	0.083244	0.081111	0.079022	0.076933	0.074844	0.072755	0.070666	0.068577	0.066488	0.064399	0.062310	0.060221
28.33	8.53	17	0.121928	0.121928	0.121732	0.121308	0.119115	0.115087	0.110557	0.108177	0.105965	0.103753	0.101541	0.099329	0.097117	0.094905	0.092693	0.090481	0.088269	0.086057	0.083845
31.67	9.07	19	0.153291	0.153291	0.15275	0.152095	0.149965	0.144845	0.139709	0.136596	0.133483	0.130370	0.127257	0.124144	0.121031	0.117918	0.114805	0.111692	0.108579	0.105466	0.102353
35.00	9.60	21	0.187681	0.187681	0.187219	0.186386	0.183583	0.177472	0.172183	0.16825	0.164317	0.160384	0.156451	0.152518	0.148585	0.144652	0.140719	0.136786	0.132853	0.128920	0.124987
38.33	10.13	23	0.225607	0.225607	0.225607	0.223669	0.220747	0.213711	0.207669	0.204123	0.201105	0.198087	0.195069	0.192051	0.189033	0.186015	0.183000	0.180000	0.177000	0.174000	0.171000
41.67	10.67	25	0.26635	0.26635	0.26635	0.264309	0.261082	0.253654	0.24654	0.242684	0.240496	0.238308	0.236120	0.233932	0.231744	0.229556	0.227368	0.225180	0.222992	0.220804	0.218616
45.00	11.20	27	0.309873	0.309873	0.309873	0.308065	0.304576	0.295002	0.289333	0.28461	0.283038	0.281465	0.279892	0.278319	0.276746	0.275173	0.273600	0.272027	0.270454	0.268881	0.267308
48.33	11.73	29	0.355824	0.355824	0.355824	0.355824	0.350289	0.341501	0.335555	0.333172	0.330868	0.328564	0.326260	0.323956	0.321652	0.319348	0.317044	0.314740	0.312436	0.310132	0.307828
51.67	12.27	31	0.406323	0.406323	0.406323	0.406323	0.400226	0.391239	0.386256	0.383911	0.382794	0.381677	0.380560	0.379443	0.378326	0.377209	0.376092	0.374975	0.373858	0.372741	0.371624
55.00	12.80	33	0.452629	0.452629	0.452629	0.452629	0.452629	0.443568	0.438844	0.437385	0.436268	0.435151	0.434034	0.432917	0.431800	0.430683	0.429566	0.428449	0.427332	0.426215	0.425098
58.33	13.33	35	0.510738	0.510738	0.510738	0.510738	0.510738	0.500194	0.496041	0.496346	0.49802	0.499696	0.501372	0.503048	0.504724	0.506400	0.508076	0.509752	0.511428	0.513104	0.514780
61.67	13.87	37	0.559426	0.559426	0.559426	0.559426	0.559426	0.559426	0.559426	0.559426	0.559426	0.559426	0.559426	0.559426	0.559426	0.559426	0.559426	0.559426	0.559426	0.559426	0.559426
65.00	14.40	39	0.618712	0.618712	0.618712	0.618712	0.618712	0.618712	0.618712	0.618712	0.618712	0.618712	0.618712	0.618712	0.618712	0.618712	0.618712	0.618712	0.618712	0.618712	0.618712
68.33	14.93	41	0.682701	0.682701	0.682701	0.682701	0.682701	0.682701	0.682701	0.682701	0.682701	0.682701	0.682701	0.682701	0.682701	0.682701	0.682701	0.682701	0.682701	0.682701	0.682701
71.67	15.47	43	0.749058	0.749058	0.749058	0.749058	0.749058	0.749058	0.749058	0.749058	0.749058	0.749058	0.749058	0.749058	0.749058	0.749058	0.749058	0.749058	0.749058	0.749058	0.749058
75.00	16.00	45	0.823741	0.823741	0.823741	0.823741	0.823741	0.823741	0.823741	0.823741	0.823741	0.823741	0.823741	0.823741	0.823741	0.823741	0.823741	0.823741	0.823741	0.823741	0.823741
78.33	16.53	47	0.899964	0.899964	0.899964	0.899964	0.899964	0.899964	0.899964	0.899964	0.899964	0.899964	0.899964	0.899964	0.899964	0.899964	0.899964	0.899964	0.899964	0.899964	0.899964
81.67	17.07	49	0.980641	0.980641	0.980641	0.980641	0.980641	0.980641	0.980641	0.980641	0.980641	0.980641	0.980641	0.980641	0.980641	0.980641	0.980641	0.980641	0.980641	0.980641	0.980641
85.00	17.60	51	1.079144	1.079144	1.079144	1.079144	1.079144	1.079144	1.079144	1.079144	1.079144	1.079144	1.079144	1.079144	1.079144	1.079144	1.079144	1.079144	1.079144	1.079144	1.079144
88.33	18.13	53	1.177848	1.177848	1.177848	1.177848	1.177848	1.177848	1.177848	1.177848	1.177848	1.177848	1.177848	1.177848	1.177848	1.177848	1.177848	1.177848	1.177848	1.177848	1.177848
91.67	18.67	55	1.268235	1.268235	1.268235	1.268235	1.268235	1.268235	1.268235	1.268235	1.268235	1.268235	1.268235	1.268235	1.268235	1.268235	1.268235	1.268235	1.268235	1.268235	1.268235
95.00	19.20	57	1.395999	1.395999	1.395999	1.395999	1.395999	1.395999	1.395999	1.395999	1.395999	1.395999	1.395999	1.395999	1.395999	1.395999	1.395999	1.395999	1.395999	1.395999	1.395999
98.33	19.73	59	1.504248	1.504248	1.504248	1.504248	1.504248	1.504248	1.504248	1.504248	1.504248	1.504248	1.504248	1.504248	1.504248	1.504248	1.504248	1.504248	1.504248	1.504248	1.504248

Valve angle = Resolver Feedback Angle – Resolve Offset Angle
 Resolver Offset Angle = ~20 degrees
 4 mA = 0° valve angle = 0 % valve position = ~20 resolver angle
 min stop = -2 degrees valve angle
 max stop = 62 degrees valve angle

3103 2.0 in² port, Effective Area Table

% travel	Driver mA	Valve Angle	Pressure Ratio (P2/P1)																
			0.05	0.15	0.25	0.35	0.45	0.55	0.65	0.75	0.85	0.95							
1.67	4.27	1	0.002419	0.002148	0.002037	0.001683	0.001265	0.001097	0.00096	0.000911	0.000876	0.000827							
5.00	4.80	3	0.007874	0.007177	0.006865	0.006546	0.006242	0.005892	0.005581	0.005399	0.005279	0.005182							
8.33	5.33	5	0.011716	0.0116504	0.0116258	0.0115983	0.0115555	0.0114843	0.0114199	0.0113758	0.0113448	0.0113292							
11.67	5.87	7	0.031216	0.031003	0.030646	0.030225	0.02947	0.028172	0.026994	0.026115	0.025485	0.025177							
15.00	6.40	9	0.051115	0.050983	0.050221	0.049317	0.048579	0.046731	0.044881	0.042712	0.041596	0.040822							
18.33	6.93	11	0.074026	0.074026	0.073605	0.073406	0.071848	0.068822	0.065682	0.063897	0.062307	0.060108							
21.67	7.47	13	0.102508	0.102508	0.101761	0.101079	0.099502	0.095418	0.091568	0.088779	0.086613	0.083901							
25.00	8.00	15	0.134842	0.134842	0.134809	0.133707	0.131335	0.125792	0.120882	0.117067	0.114711	0.112719							
28.33	8.53	17	0.172125	0.172125	0.171827	0.170514	0.166923	0.160766	0.154643	0.150549	0.147051	0.144979							
31.67	9.07	19	0.213751	0.213751	0.213219	0.212483	0.208023	0.199912	0.192592	0.186929	0.184062	0.182352							
35.00	9.60	21	0.25926	0.25926	0.25926	0.257323	0.251594	0.242773	0.23535	0.229494	0.225466	0.223829							
38.33	10.13	23	0.306389	0.306389	0.306389	0.305598	0.299747	0.289753	0.281592	0.275951	0.27245	0.271474							
41.67	10.67	25	0.360525	0.360525	0.360525	0.358722	0.352119	0.340968	0.33228	0.328254	0.32492	0.325606							
45.00	11.20	27	0.41418	0.41418	0.41418	0.41418	0.407467	0.396576	0.385056	0.384244	0.382409	0.383905							
48.33	11.73	29	0.471722	0.471722	0.471722	0.471722	0.467555	0.454539	0.448994	0.444711	0.445984	0.448668							
51.67	12.27	31	0.529984	0.529984	0.529984	0.529984	0.529984	0.516409	0.511364	0.514637	0.516962	0.521363							
55.00	12.80	33	0.598056	0.598056	0.598056	0.598056	0.598056	0.58592	0.581764	0.588404	0.59174	0.58875							
58.33	13.33	35	0.671635	0.671635	0.671635	0.671635	0.671635	0.663707	0.661849	0.666392	0.676142	0.687348							
61.67	13.87	37	0.741153	0.741153	0.741153	0.741153	0.741153	0.741153	0.743053	0.744898	0.760309	0.770029							
65.00	14.40	39	0.82314	0.82314	0.82314	0.82314	0.82314	0.82314	0.827088	0.842855	0.857134	0.87362							
68.33	14.93	41	0.92638	0.92638	0.92638	0.92638	0.92638	0.92638	0.92638	0.92638	0.948472	0.96654							
71.67	15.47	43	1.043737	1.043737	1.043737	1.043737	1.043737	1.043737	1.043737	1.043737	1.043737	1.062126							
75.00	16.00	45	1.142775	1.142775	1.142775	1.142775	1.142775	1.142775	1.142775	1.142775	1.142775	1.166762							
78.33	16.53	47	1.261553	1.261553	1.261553	1.261553	1.261553	1.261553	1.261553	1.261553	1.261553	1.261553							
81.67	17.07	49	1.380397	1.380397	1.380397	1.380397	1.380397	1.380397	1.380397	1.380397	1.380397	1.380397							
85.00	17.60	51	1.478962	1.478962	1.478962	1.478962	1.478962	1.478962	1.478962	1.478962	1.478962	1.478962							
88.33	18.13	53	1.617188	1.617188	1.617188	1.617188	1.617188	1.617188	1.617188	1.617188	1.617188	1.617188							
91.67	18.67	55	1.717185	1.717185	1.717185	1.717185	1.717185	1.717185	1.717185	1.717185	1.717185	1.717185							
95.00	19.20	57	1.883471	1.883471	1.883471	1.883471	1.883471	1.883471	1.883471	1.883471	1.883471	1.883471							
98.33	19.73	59	1.983762	1.983762	1.983762	1.983762	1.983762	1.983762	1.983762	1.983762	1.983762	1.983762							

Valve angle = Resolver Feedback Angle – Resolve Offset Angle
 Resolver Offset Angle = ~20 degrees
 4 mA = 0° valve angle = 0 % valve position = ~20 resolver angle
 min stop = -2 degrees valve angle
 max stop = 62 degrees valve angle

Chapter 7. Maintenance

There are no critical maintenance items in the 3103/EM-35MR gas valve assemblies, such as filters that should be changed, etc. The valve assembly should be visually inspected, in accordance with your specific maintenance schedule. Each site must determine the appropriate schedule based on the severity of the service conditions. Valve maintenance frequency should increase if the turbine is operated under a low duty cycle, where the valve is required to be in a standby mode for extended periods of time. Inspect for dirt, grease, dust, or other buildup in the areas of moving parts or joints. Clean environmentally originated buildup from the unit; if cleaning solution is used, verify that it is compatible with the Viton[®] * and Teflon[®] * valve seal materials. If any buildup appears to have originated from within the valve, return the valve to Woodward for service (see Chapter 8).

*—Viton is a registered trademark of DuPont Performance Elastomers.
Teflon is a registered trademark of the DuPont Company.

Chapter 8. Service Options

Product Service Options

If you are experiencing problems with the installation, or unsatisfactory performance of a Woodward product, the following options are available:

- Consult the troubleshooting guide in the manual.
- Contact the manufacturer or packager of your system.
- Contact the Woodward Full Service Distributor serving your area.
- Contact Woodward technical assistance (see “How to Contact Woodward” later in this chapter) and discuss your problem. In many cases, your problem can be resolved over the phone. If not, you can select which course of action to pursue based on the available services listed in this chapter.

OEM and Packager Support: Many Woodward controls and control devices are installed into the equipment system and programmed by an Original Equipment Manufacturer (OEM) or Equipment Packager at their factory. In some cases, the programming is password-protected by the OEM or packager, and they are the best source for product service and support. Warranty service for Woodward products shipped with an equipment system should also be handled through the OEM or Packager. Please review your equipment system documentation for details.

Woodward Business Partner Support: Woodward works with and supports a global network of independent business partners whose mission is to serve the users of Woodward controls, as described here:

- A **Full Service Distributor** has the primary responsibility for sales, service, system integration solutions, technical desk support, and aftermarket marketing of standard Woodward products within a specific geographic area and market segment.
- An **Authorized Independent Service Facility (AISF)** provides authorized service that includes repairs, repair parts, and warranty service on Woodward's behalf. Service (not new unit sales) is an AISF's primary mission.
- A **Recognized Engine Retrofitter (RER)** is an independent company that does retrofits and upgrades on reciprocating gas engines and dual-fuel conversions, and can provide the full line of Woodward systems and components for the retrofits and overhauls, emission compliance upgrades, long term service contracts, emergency repairs, etc.
- A **Recognized Turbine Retrofitter (RTR)** is an independent company that does both steam and gas turbine control retrofits and upgrades globally, and can provide the full line of Woodward systems and components for the retrofits and overhauls, long term service contracts, emergency repairs, etc.

You can locate your nearest Woodward distributor, AISF, RER, or RTR on our website at:

www.woodward.com/directory.aspx

Woodward Factory Servicing Options

The following factory options for servicing Woodward products are available through your local Full-Service Distributor or the OEM or Packager of the equipment system, based on the standard Woodward Product and Service Warranty (5-01-1205) that is in effect at the time the product is originally shipped from Woodward or a service is performed:

- Replacement/Exchange (24-hour service)
- Flat Rate Repair
- Flat Rate Remanufacture

Replacement/Exchange: Replacement/Exchange is a premium program designed for the user who is in need of immediate service. It allows you to request and receive a like-new replacement unit in minimum time (usually within 24 hours of the request), providing a suitable unit is available at the time of the request, thereby minimizing costly downtime. This is a flat-rate program and includes the full standard Woodward product warranty (Woodward Product and Service Warranty 5-01-1205).

This option allows you to call your Full-Service Distributor in the event of an unexpected outage, or in advance of a scheduled outage, to request a replacement control unit. If the unit is available at the time of the call, it can usually be shipped out within 24 hours. You replace your field control unit with the like-new replacement and return the field unit to the Full-Service Distributor.

Charges for the Replacement/Exchange service are based on a flat rate plus shipping expenses. You are invoiced the flat rate replacement/exchange charge plus a core charge at the time the replacement unit is shipped. If the core (field unit) is returned within 60 days, a credit for the core charge will be issued.

Flat Rate Repair: Flat Rate Repair is available for the majority of standard products in the field. This program offers you repair service for your products with the advantage of knowing in advance what the cost will be. All repair work carries the standard Woodward service warranty (Woodward Product and Service Warranty 5-01-1205) on replaced parts and labor.

Flat Rate Remanufacture: Flat Rate Remanufacture is very similar to the Flat Rate Repair option with the exception that the unit will be returned to you in “like-new” condition and carry with it the full standard Woodward product warranty (Woodward Product and Service Warranty 5-01-1205). This option is applicable to mechanical products only.

Returning Equipment for Repair

If a control (or any part of an electronic control) is to be returned for repair, please contact your Full-Service Distributor in advance to obtain Return Authorization and shipping instructions.

When shipping the item(s), attach a tag with the following information:

- return authorization number;
- name and location where the control is installed;
- name and phone number of contact person;
- complete Woodward part number(s) and serial number(s);
- description of the problem;
- instructions describing the desired type of repair.

Packing a Control

Use the following materials when returning a complete control:

- protective caps on any connectors;
- antistatic protective bags on all electronic modules;
- packing materials that will not damage the surface of the unit;
- at least 100 mm (4 inches) of tightly packed, industry-approved packing material;
- a packing carton with double walls;
- a strong tape around the outside of the carton for increased strength.

NOTICE

To prevent damage to electronic components caused by improper handling, read and observe the precautions in Woodward manual 82715, *Guide for Handling and Protection of Electronic Controls, Printed Circuit Boards, and Modules*.

Replacement Parts

When ordering replacement parts for controls, include the following information:

- the part number(s) (XXXX-XXXX) that is on the enclosure nameplate;
- the unit serial number, which is also on the nameplate.

Engineering Services

Woodward offers various Engineering Services for our products. For these services, you can contact us by telephone, by email, or through the Woodward website.

- Technical Support
- Product Training
- Field Service

Technical Support is available from your equipment system supplier, your local Full-Service Distributor, or from many of Woodward's worldwide locations, depending upon the product and application. This service can assist you with technical questions or problem solving during the normal business hours of the Woodward location you contact. Emergency assistance is also available during non-business hours by phoning Woodward and stating the urgency of your problem.

Product Training is available as standard classes at many of our worldwide locations. We also offer customized classes, which can be tailored to your needs and can be held at one of our locations or at your site. This training, conducted by experienced personnel, will assure that you will be able to maintain system reliability and availability.

Field Service engineering on-site support is available, depending on the product and location, from many of our worldwide locations or from one of our Full-Service Distributors. The field engineers are experienced both on Woodward products as well as on much of the non-Woodward equipment with which our products interface.

For information on these services, please contact us via telephone, email us, or use our website: www.woodward.com.

How to Contact Woodward

For assistance, call one of the following Woodward facilities to obtain the address and phone number of the facility nearest your location where you will be able to get information and service.

Electrical Power Systems

Facility	Phone Number
Brazil	+55 (19) 3708 4800
China	+86 (512) 6762 6727
Germany	+49 (0) 21 52 14 51
India	+91 (129) 4097100
Japan	+81 (43) 213-2191
Korea	+82 (51) 636-7080
Poland	+48 12 295 13 00
United States	+1 (970) 482-5811

Engine Systems

Facility	Phone Number
Brazil	+55 (19) 3708 4800
China	+86 (512) 6762 6727
Germany	+49 (711) 78954-0
India	+91 (129) 4097100
Japan	+81 (43) 213-2191
Korea	+82 (51) 636-7080
The Netherlands	+31 (23) 5661111
United States	+1 (970) 482-5811

Turbine Systems

Facility	Phone Number
Brazil	+55 (19) 3708 4800
China	+86 (512) 6762 6727
India	+91 (129) 4097100
Japan	+81 (43) 213-2191
Korea	+82 (51) 636-7080
The Netherlands	+31 (23) 5661111
Poland	+48 12 295 13 00
United States	+1 (970) 482-5811

You can also locate your nearest Woodward distributor or service facility on our website at:

www.woodward.com/directory.aspx

Technical Assistance

If you need to telephone for technical assistance, you will need to provide the following information. Please write it down here before phoning:

Your Name _____

Site Location _____

Phone Number _____

Fax Number _____

Engine/Turbine Model Number _____

Manufacturer _____

Number of Cylinders (if applicable) _____

Type of Fuel (gas, gaseous, steam, etc) _____

Rating _____

Application _____

Control/Governor #1

Woodward Part Number & Rev. Letter _____

Control Description or Governor Type _____

Serial Number _____

Control/Governor #2

Woodward Part Number & Rev. Letter _____

Control Description or Governor Type _____

Serial Number _____

Control/Governor #3

Woodward Part Number & Rev. Letter _____

Control Description or Governor Type _____

Serial Number _____

If you have an electronic or programmable control, please have the adjustment setting positions or the menu settings written down and with you at the time of the call.

3103/EM-35MR Specifications

The EM-35MR electric actuator was designed for the positioning of Woodward gas and liquid valves equipped with resolver feedback. The actuator requires a final driver for driving the motor and for closed loop control.

The EM-35MR actuator uses a brushless dc motor with a reducing planetary gearhead. The motor is designed with Samarium Cobalt permanent magnets bonded to the rotor element and all stator windings are completely sealed. Rotor position sensing is performed by the field director unit integral with the motor. This inductive device requires excitation and demodulation within the electronic motor controller.

Mechanical

Output shaft rotation	60° (Rotation limited by valve stops)
Actuator/valve coupling	Direct Coupling
Torque constant	1.8 N·m/A (16 lb-in/A)
Continuous output torque	±25 N·m (±220 lb-in) maximum
Peak output torque	±62 N·m (±552 lb-in) minimum
Clutch breakaway torque	±68 N·m (±600 lb-in)
Valve gas connection	2 inch 600# ANSI B16.5 (50 mm, 2669 N)
Gas flow	(23 to 18 144) kg/h / (50 to 40 000) lb/h natural gas
Gas pressure	(0 to 6205) kPa / (0 to 900) psia (0 to 4964) kPa / (0 to 720) psia (restriction for CE Marking)
Gas filtration	25 µm absolute at 75 beta requirement
Minimum pressure differential	Non-DLE: 172 kPa (25 psid) DLE: 345 kPa (50 psid)

Electrical

Power input	28 V (dc) nominal, (18 to 32) V (dc) operating, 15 A continuous, 37 A peak for 50 ms
-------------	--

Performance

Slew time (50 deg)	150 ms open, 80 ms close at 28 V and room temperature (100 ms close for 137:1 gear ratio) where slew time = valve travel ÷ max slew rate
Bandwidth	>5 Hz
Position accuracy	±0.50° analog, ±6 arc min RSS (root sum squared) digital

IMPORTANT

Flow metering accuracy and performance are not guaranteed above 4964 kPa (720 psia) maximum.

Environmental

Ambient Temperature and Fuel Temperature	(-40 to +149) °C / (-40 to +300) °F
Ambient Temperature and Fuel Temperature (Restriction for CE Marking)	(-29 to +149) °C / (-20 to +300) °F
Vibration	US MIL-STD-810C Method 514.2, Category b.1, Table 514.2-II, Figure 514.2 curve j (5 G)
Shock	US MIL-STD-810C, Method 516.2, Figure 516.2-1, 20 G 11 ms sawtooth

Revision History

Changes in Revision J—

- Added 'General Conditions for Safe Use' warning to Regulatory Compliance pages
- Added instructions to Chapter 1 about preventing excessive wear in standby applications
- Added operational notices to Chapter 1
- Added wiring notice and shock hazard warning to Chapter 2
- Added several valve positioning warnings to Chapter 4
- Add Troubleshooting table to Chapter 5
- Added information to Chapter 7 about maintenance frequency in standby applications
- Added flow metering maximum note to Specifications

Declaration of Incorporation

Woodward Governor Company
1000 E. Drake Road
Fort Collins, Colorado 80525
United States of America

Product: EM35 and EM35MR1 Actuators
Part Number: 9907-XXX

The undersigned hereby declares, on behalf of Woodward Governor Company of Loveland and Fort Collins, Colorado, that the above-referenced product is in conformity with the following EU Directives as they apply to a component:

98/37/EEC (Machinery)

This product is intended to be put into service only upon incorporation into an apparatus/system that itself will meet the requirements of the above Directives and bears the CE mark.

Manufacturer



Signature

Douglas W. Salter

Full Name

Engineering Manager

Position

WGC, Fort Collins, CO, USA

Location

10/28/02

Date

Declaration of Incorporation

Woodward Governor Company
1000 E. Drake Road
Fort Collins, Colorado 80525
United States of America

Product: EM/TM Resolvers
Part Number: 9907-XXX

The undersigned hereby declares, on behalf of Woodward Governor Company of Loveland and Fort Collins, Colorado, that the above-referenced product is in conformity with the following EU Directives as they apply to a component:

98/37/EEC (Machinery)

This product is intended to be put into service only upon incorporation into an apparatus/system that itself will meet the requirements of the above Directives and bears the CE mark.

Manufacturer



Signature

Douglas W. Salter

Full Name

Engineering Manager

Position

WGC, Fort Collins, CO, USA

Location

10/28/02

Date

Declaration of Incorporation

Woodward Governor Company
1000 E. Drake Road
Fort Collins, Colorado 80525
United States of America

Product: 3103 Gas Valves
Part Number: Part Numbers 6945-XXXX

The undersigned hereby declares, on behalf of Woodward Governor Company of Loveland and Fort Collins, Colorado, that the above-referenced product is in conformity with the following EU Directives as they apply to a component:

98/37/EC (Machinery)

This product is intended to be put into service only upon incorporation into an apparatus/system that itself will meet the requirements of the above Directives and bears the CE mark.

MANUFACTURER



Signature
Dan Gear

Full Name
Director of Engineering

Position
WGC, Fort Collins, CO, USA

Place

Date
4/12/07

DECLARATION OF CONFORMITY

Manufacturer's Name: WOODWARD GOVERNOR COMPANY (WGC)
Industrial Controls Group

Manufacturer's Address: 1000 E. Drake Rd.
Fort Collins, CO, USA, 80525

Model Name(s)/Number(s): EM35 and EM35MR1 Actuators

Conformance to Directive(s): 94/9/EC COUNCIL DIRECTIVE of 23 March 1994 on the approximation of the laws of the Member States concerning equipment and protective systems intended for use in potentially explosive atmospheres

Marking(s): Category 2, Group II G, EEx d IIB T3 X

Applicable Standards: EN50014, 1998: Electrical apparatus for potentially explosive atmospheres - General Requirements
EN50018, 2000: Electrical apparatus for potentially explosive atmospheres - Flameproof enclosure 'd'

3rd Party Certification LCIE 02 ATEX 6140 X

Conformity Assessment: ATEX Production Quality Assessment, ITS05ATEXQ4211

Notified Body Intertek (0359)
For ATEX: Leatherhead, Surrey,
Intertek House, Cleeve Road
KT22 7SB UK

We, the undersigned, hereby declare that the equipment specified above conforms to the above Directive(s).

MANUFACTURER

Signature



Full Name

DAN GEAR

Position

Engineering Manager

Place

WGC, Fort Collins, CO, USA

Date

8/17/05

DECLARATION OF CONFORMITY

Manufacturer's Name: WOODWARD GOVERNOR COMPANY (WGC)
Industrial Controls Group

Manufacturer's Address: 1000 E. Drake Rd.
Fort Collins, CO, USA, 80525

Model Name(s)/Number(s): EM/TM Resolvers

Conformance to Directive(s): 94/9/EC COUNCIL DIRECTIVE of 23 March 1994 on the approximation of the laws of the Member States concerning equipment and protective systems intended for use in potentially explosive atmospheres

Marking(s): Category 2, Group II G, EEx d IIB T3 X

Applicable Standards: EN50014, 1998: Electrical apparatus for potentially explosive atmospheres - General Requirements
EN50018, 2000: Electrical apparatus for potentially explosive atmospheres - Flameproof enclosure 'd'

3rd Party Certification LCIE 02 ATEX 6141 X

Conformity Assessment: ATEX Production Quality Assessment, ITS05ATEXQ4211

Notified Body Intertek (0359)
For ATEX: Intertek House, Cleeve Road
Leatherhead, Surrey,
KT22 7SB UK

We, the undersigned, hereby declare that the equipment specified above conforms to the above Directive(s).

MANUFACTURER

Signature



Full Name

DAN GEAN

Position

Engineering Manager

Place

WGC, Fort Collins, CO, USA

Date

8/17/05

DECLARATION OF CONFORMITY

Manufacturer's Name: WOODWARD GOVERNOR COMPANY (WGC)
Industrial Controls Group

Manufacturer's Address: 1000 E. Drake Rd.
Fort Collins, CO, USA, 80525

Model Name(s)/Number(s): 3103 Gas Valves, 6945-1165, 6945-1166, 6945-1167, 6945-1168

Conformance to Directive(s): 97/23/EC COUNCIL DIRECTIVE of 29 May 1997 on the approximation of the laws of the Member States concerning Pressure Equipment
94/9/EC COUNCIL DIRECTIVE of 23 March 1994 on the approximation of the laws of the Member States concerning equipment and protective systems intended for use in potentially explosive atmospheres

Marking(s):  2 IIG c II X

Applicable Standards: ASME B31.3 Process Piping, 2004
ASME Boiler and Pressure Vessel Code VIII, Div. 1, 2007
ASME Boiler and Pressure Vessel Code II, Part D, 2007
EN 13463-1:2002, Cor 2002, Non-Electrical Equipment for Potentially Explosive Atmospheres – Part 1: Basic Method and Requirements
EN 13463-5:2003, Non-Electrical Equipment for Potentially Explosive Atmospheres – Part 5: Protection by Constructional Safety “c”

Conformity Assessment: PED Module H – Full Quality Assurance, Certificate 90174

Notified Body Moody International Certification Limited (1277)
For Pressure Equipment: Merlin House, Stanier Way
Wyvern Business Park
Derby DE21 6BF United Kingdom

We, the undersigned, hereby declare that the equipment specified above conforms to the above Directive(s).

MANUFACTURER



Signature

Joseph Driscoll
Full Name

Engineering Manager
Position

WGC, Fort Collins, CO, USA
Place

7/31/08
Date

We appreciate your comments about the content of our publications.

Send comments to: icinfo@woodward.com

Please reference publication **40185J**.



B40185:J



PO Box 1519, Fort Collins CO 80522-1519, USA
1000 East Drake Road, Fort Collins CO 80525, USA
Phone +1 (970) 482-5811 • Fax +1 (970) 498-3058

Email and Website—www.woodward.com

Woodward has company-owned plants, subsidiaries, and branches,
as well as authorized distributors and other authorized service and sales facilities throughout the world.

Complete address / phone / fax / email information for all locations is available on our website.