

TG Governors

Application

The TG Governors are self-contained, mechanical-hydraulic, speed droop governors for use on small steam turbines where isochronous (constant speed) operation is not required.

Standard Features

Simplicity and low cost are distinct advantages of the TG Governors. The governors operate with speed droop for stability of control.

An internal oil pump, driven by the governor's drive shaft, transports oil from the self-contained sump. Internal pressure is maintained by a relief valve-accumulator system. An oil sight-glass provides ease in checking the oil level.

The output (terminal) shaft extends out both sides of the case, and the governor drive rotation can be in either direction.

TG Governors are available in two different work outputs: 16 N·m (12 lb-ft) for the TG-13 and 23.7 N·m (17.5 lb-ft) for the TG-17. Two different types of speed-setting adjustments are available for each power output. Screw speed-setting is standard and lever speed-setting is optional.

This unit is hydraulically powered for a high work output and is available for three speed ranges.

Special Features

The built-in relief valve-accumulator helps maintain full oil pressure in the governor hydraulic system during transient conditions.

Contamination is reduced by the weatherproof construction and the self-contained oil sump.

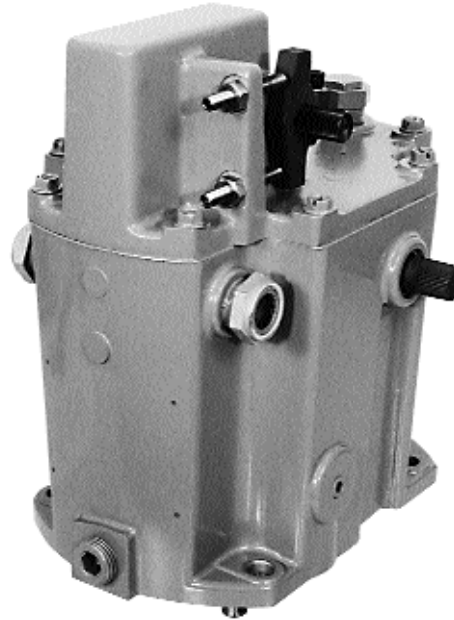

Lever Speed Setting Type

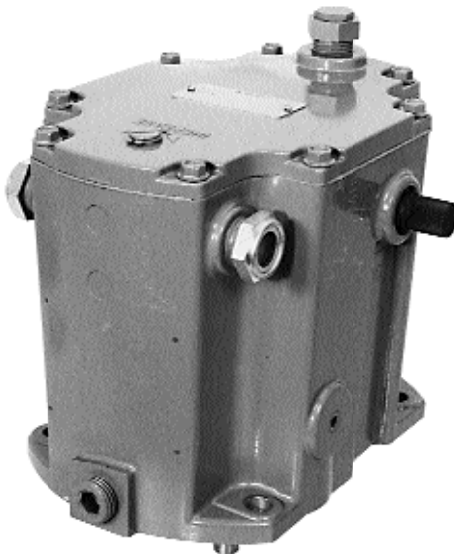

Screw Speed Setting Type

- Low cost
- Speed droop control
- Weatherproof
- Self-contained sump
- NEMA "A"
- 16 and 23.7 N·m (12 and 17.5 lb-ft) outputs
- Models are available compliant with the applicable CE Directives—ATEX, Pressure Equipment, Machinery

Specifications

Screw	Adjustment on top of cover
Shaft	.500-36 serration on both sides of cover
Speed Range	Can be adjusted to meet NEMA "A" requirements at any speed within the following ranges: 1100 to 2400 rpm 2400 to 4000 rpm 4000 to 6000 rpm Different governor part numbers are required for different ranges.

IMPORTANT

Both governors are capable of controlling at lower-than-specified speed range with some loss of output torque and performance.

Drive Power Requirement	373 W (1/2 hp) maximum required to turn drive shaft at rated speed
Rotation	Clockwise or counterclockwise, as viewed from the top of the governor

IMPORTANT

Rotation can be changed on the die cast aluminum governor by removing four screws and rotating pump housing 180°. On the cast-iron governor, it can be changed internally.

Output

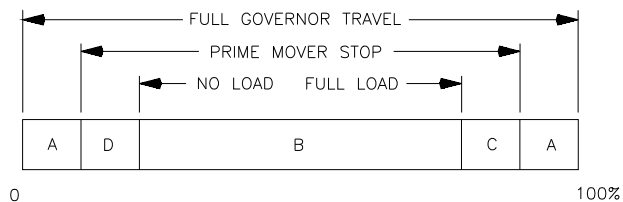
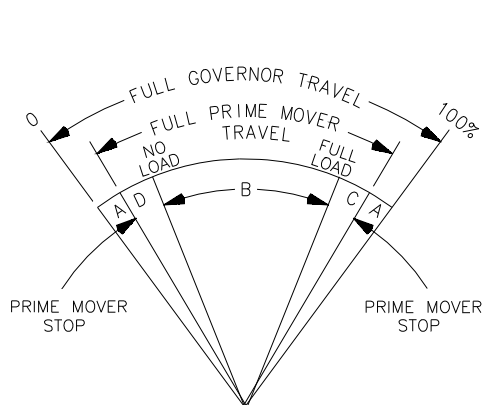

- A – OVERTRAVEL TO INSURE PRIME MOVER STOPS ARE REACHED.
- B – NO LOAD TO FULL LOAD TRAVEL – NORMALLY 2/3 OF FULL GOVERNOR TRAVEL IS RECOMMENDED.
- C – TRAVEL REQUIRED TO ACCELERATE THE PRIME MOVER.
- D – TRAVEL REQUIRED TO DECELERATE OR SHUT DOWN PRIME MOVER.

MI-153a
98-04-14 skw

MAXIMUM WORK CAPACITY OVER FULL GOVERNOR TRAVEL OF 42° IS * . SEE ABOVE FOR RECOMMENDED GOVERNOR OUTPUT TRAVEL. IN SPECIAL APPLICATIONS MIN AND MAX PRIME MOVER STOPS MAY BE OUTSIDE THE GOVERNOR STOPS.

TG-13	16 N·m (12 lb-ft)
TG-17	23.7 N·m (17.5 lb-ft)
Output Shaft	.625-36 serration on both sides of case

Control Characteristics

(intended to meet NEMA "A" requirements)

Steady State Speed Band	±0.75% of rated speed
Drop	Internally adjustable and must be set as required for stability. Factory set at 6% for 20° terminal shaft travel at 1800, 3600, or 5400 rpm, depending on speed range selected.
Typical Response	7.2% overspeed with full load change on a 50% per second acceleration turbine at 4% droop setting
Operating Temperature	Continuous operating temperature 60 to 93 °C (140 to 200 °F). Ambient temperature -29 to +93 °C (-20 to +200 °F). Contact Woodward if operating beyond these limits.

Hydraulic System

Oil	Self-contained sump. SAE 10 to 50 is recommended with a viscosity of 100 to 300 SUS, depending on operating temperature. See Woodward manual 25071, <i>Oils for Hydraulic Controls</i> , for recommended oils.
Relief Valve	An integral part of accumulator—it maintains 1034 kPa (150 psi) for the TG-13 and 1379 kPa (200 psi) for the TG-17 at the specified speed ranges. Both governors are capable of controlling at lower speeds with some loss of output torque and performance.
Capacity	1.7 L (1.75 quarts)

Construction

Case and Pump Housing	Die cast aluminum
Weight	7 kg (16 lb) aluminum case

Mounting

Attitude	Vertical or horizontal (breather cap up)
----------	--

References

Manual 04042, *TG-13 and TG-17 Governors*
 Manual 25071, *Oils for Hydraulic Control*

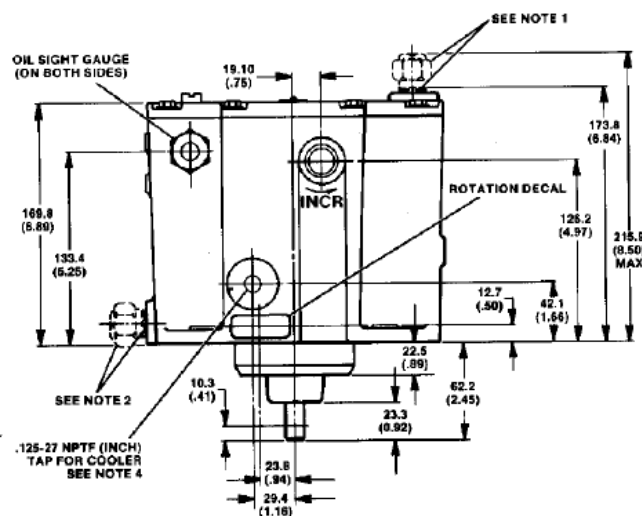
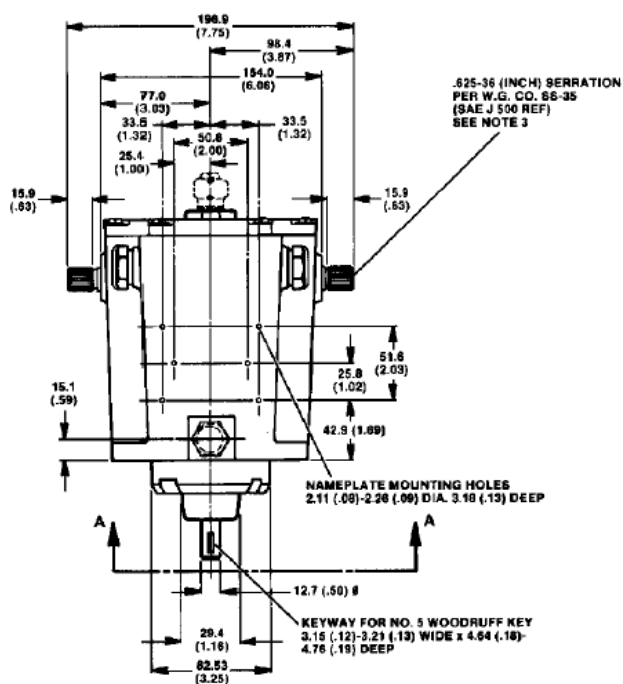
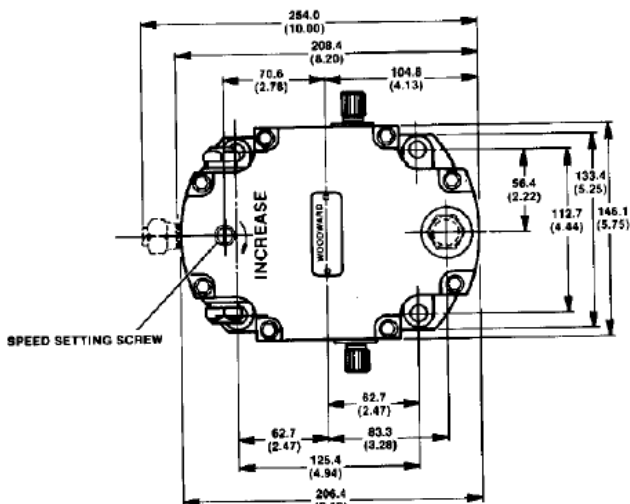
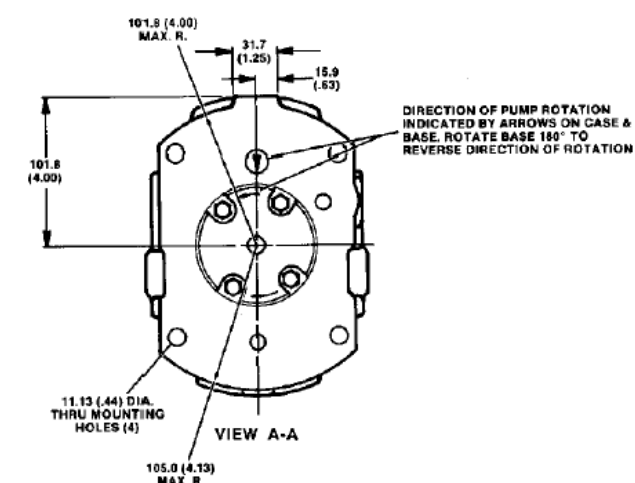

NOTES:

1. OIL FILL PORT/BREATHER FILTER CAP LOCATION WHEN GOVERNOR IS MOUNTED VERTICALLY. OIL DRAIN PLUG LOCATION WHEN GOVERNOR IS MOUNTED HORIZONTALLY.
2. OIL FILL PORT/BREATHER FILTER CAP LOCATION WHEN GOVERNOR IS MOUNTED HORIZONTALLY. OIL DRAIN PLUG LOCATION WHEN GOVERNOR IS MOUNTED VERTICALLY.
3. TERMINAL OUTPUT SHAFT MAX AVAILAE STROKE IS 46° RECOMMENDED STRO FROM NO LOAD TO FULL LOAD IS 27°.
4. COOLER TAP OUTPUT (USED ON 6000 R GOV.) COOLER RETURN TO BE CONNECT TO GOVERNOR DRAIN.
5. INCHES ARE SHOWN IN PARENTHESES.

(DO NOT USE FOR CONSTRUCTION)

Outline Drawing of TG-13 and TG-17 Governors (screw speed setting)

Regulatory Compliance

European Compliance for CE Marking:

(Applicable only to units bearing the CE marking.)

ATEX Potentially Explosive Atmospheres Directive:

Declared to 94/9/EC COUNCIL DIRECTIVE of 23 March 1994 on the approximation of the laws of the Member States concerning equipment and protective systems intended for use in potentially explosive atmospheres as: II 2G c II X. The X reflects special conditions for safe use:

Special Conditions for Safe Use – Maximum Surface Temperature

The maximum surface temperature of the TG Governor is dependent upon three factors that are specific to the operating conditions of each individual application. These factors are as follows:

- Governor drive shaft speed
- Ambient temperature
- Hydraulic Fluid Selection (see Table 2-1 in manual 04042)

The maximum surface temperature of the TG Governor must stay below the lowest ignition temperature of the surrounding explosive atmosphere and within allowable operating conditions for the hydraulic fluid selection. It is the user's responsibility to maintain a safe surface and fluid temperature. If normal operating conditions cause the surface temperature of the TG to rise close to ignition temperatures or near the maximum recommended hydraulic fluid temperature, a heat exchanger must be installed. Refer to manual 04042 for location and sizing of the ports for connection of a heat exchanger.

Other European Compliance

Compliance with the following European Directive does not qualify this product for the application of the CE Marking:

Machinery Directive:

Compliant as partly completed machinery with Directive 2006/42/EC of the European Parliament and the Council of 17 May 2006 on machinery.

Pressure Equipment Directive:

Compliant as "SEP" per Article 3.3 to Pressure Equipment Directive 97/23/EC of 29 May 1997 on the approximation of the laws of the Member States concerning pressure equipment.



PO Box 1519, Fort Collins CO, USA 80522-1519
1000 East Drake Road, Fort Collins CO 80525
Tel.: +1 (970) 482-5811 • Fax: +1 (970) 498-3058
www.woodward.com

Distributors & Service

Woodward has an international network of distributors and service facilities. For your nearest representative, call the Fort Collins plant or see the Worldwide Directory on our website.

This document is distributed for informational purposes only. It is not to be construed as creating or becoming part of any Woodward contractual or warranty obligation unless expressly stated in a written sales contract.

© Woodward 1983, All Rights Reserved

For more information contact:

2011/4/Colorado