



Technical Supplement

**ProAct™ II
Digital Speed Control System**

Manual 36060

IMPORTANT



This is the safety alert symbol. It is used to alert you to potential personal injury hazards. Obey all safety messages that follow this symbol to avoid possible injury or death.

DEFINITIONS

- **DANGER**—Indicates a hazardous situation which, if not avoided, will result in death or serious injury.
- **WARNING**—Indicates a hazardous situation which, if not avoided, could result in death or serious injury.
- **CAUTION**—Indicates a hazardous situation which, if not avoided, could result in minor or moderate injury.
- **NOTICE**—Indicates a hazard that could result in property damage only (including damage to the control).
- **IMPORTANT**—Designates an operating tip or maintenance suggestion.

WARNING

The engine, turbine, or other type of prime mover should be equipped with an overspeed shutdown device to protect against runaway or damage to the prime mover with possible personal injury, loss of life, or property damage.

The overspeed shutdown device must be totally independent of the prime mover control system. An overtemperature or overpressure shutdown device may also be needed for safety, as appropriate.



Read this entire manual and all other publications pertaining to the work to be performed before installing, operating, or servicing this equipment. Practice all plant and safety instructions and precautions. Failure to follow instructions can cause personal injury and/or property damage.



This publication may have been revised or updated since this copy was produced. To verify that you have the latest revision, be sure to check the Woodward website:

www.woodward.com/pubs/current.pdf

The revision level is shown at the bottom of the front cover after the publication number. The latest version of most publications is available at:

www.woodward.com/publications

If your publication is not there, please contact your customer service representative to get the latest copy.



Any unauthorized modifications to or use of this equipment outside its specified mechanical, electrical, or other operating limits may cause personal injury and/or property damage, including damage to the equipment. Any such unauthorized modifications: (i) constitute "misuse" and/or "negligence" within the meaning of the product warranty thereby excluding warranty coverage for any resulting damage, and (ii) invalidate product certifications or listings.

NOTICE

To prevent damage to a control system that uses an alternator or battery-charging device, make sure the charging device is turned off before disconnecting the battery from the system.

NOTICE

To prevent damage to electronic components caused by improper handling, read and observe the precautions in Woodward manual 82715, *Guide for Handling and Protection of Electronic Controls, Printed Circuit Boards, and Modules*.

ProAct™ II

Digital Speed Control System

General Description

This section gives an overview of the functions and the operation of the ProAct™ II control system. If you want to have more detailed information concerning the description or principle of operation of the ProAct II Digital Speed Control system, refer to Woodward manual 04121.

ProAct Digital Speed Control

The ProAct digital speed control uses a 16-bit microprocessor to control functions, such as computing engine speed, performing the control algorithm calculations, speed ramps, etc. All control adjustments are made with the handheld programmer.

Handheld Programmer

The handheld programmer is a handheld terminal to adjust the different parameters of the ProAct II speed control. The handheld programmer gets its power supply through the ProAct digital speed control. You can adjust the program with the handheld programmer through seven menus.

Speed Sensor

The speed sensor (magnetic pickup) senses the engine speed and converts it to an ac signal from 1–60 Vrms, to the ProAct II speed control. The speed sensor contains a special tracking filter, for reciprocating engines, which minimizes the effects of engine torsionals and irregularities in the gear.

ProAct Actuator

The ProAct actuator is a limited-angle rotational torque motor to control the engine fuel. The torque motor is a “run-hold” device, which responds to a fuel position error at full speed until the position feedback causes the electronic control to change the current signal to the hold position. The ProAct actuator provides 7.1 J (5.2 ft-lb) of work (transient) and 2.7 J (2.0 ft-lb) at steady state.

The feedback device on the ProAct actuator gives a feedback signal to the ProAct digital speed control for accurate positioning of the actuator. The feedback device is a brushless, magnetic-resistance position sensor.

Operation

This section describes the operation and main features of the ProAct II control, such as speed sensing, speed control, speed references and fuel limits. See Figure 1, Block Diagram ProAct II System.

Speed Sensing

The speed sensing of the engine is done by the speed sensor (MPU). The ProAct II speed control compares the speed sensor signal with the reference voltage (speed reference) at the summing point.

Speed Control

The speed control part sets the engine fuel rack position to maintain the requested engine speed. The speed control part consists of the PID control, the Low Signal Select (LSS) bus and the actuator.

The PID control compares the actual speed with the speed reference, and determines the response of the actuator signal with an increase or decrease in speed. The actuator signal changes until the actual speed and the speed reference are the same. For the dynamics settings of the PID control, see Menu 1—Dynamics Menu below. The LSS bus uses the lowest signal to control the actuator output. The actuator output is a PWM signal.

Speed Reference

The speed reference limits are parameters which you can adjust as described in Menu 3—Speed Reference Menu below. The speed reference can be controlled with the following switches:

- IDLE/RATED switch
- RAISE switch
- LOWER switch
- ISOCH/DROOP switch
- REMOTE SPEED REF switch

1 IDLE/RATED Switch

The ProAct II control uses this switch to determine the desired engine speed. When you close this switch, the ProAct II control ramps the setpoint to the rated setting. When you leave the switch open, the ProAct II control immediately ramps to the idle setting. The idle selection disables the raise, lower and remote ref functions.

2 RAISE Switch

When you close this switch, the ProAct II control raises the setpoint at a pre-determined rate. When you leave the switch open, the engine speed remains at its current value. The “RAISE” selection cancels the accel or decel ramp.

3 LOWER Switch

When you close the “LOWER” switch, the ProAct II control lowers the setpoint at a pre-determined rate. When you leave the switch open, the setpoint remains at its current value. The “LOWER” selection cancels the accel or decel ramp.

4 ISOCH/DROOP Switch

The ProAct II control provides an input for the user to select between isochronous engine control or droop. When you leave the “ISOCH/DROOP” switch open, the ProAct II control holds the engine speed to a droop schedule installed in the programmer. The droop is based on the control output. For example, 5% droop setting gives a real droop of 2.5% if the control output changes 50% from no load to full load.

5 REMOTE SPEED REF 4–20 mA

The speed reference or setpoint is controlled by a 4–20 mA signal, when the switch is in the active position and a signal is applied to terminals 14 and 15.

Fuel Limiters

The speed control has the possibility to use different fuel limits, which are the start fuel limit, the max fuel limit and the torque limit. The start fuel limit limits the fuel rack position when you start the engine. The start fuel limit prevents overfueling during start-up. The ProAct II control reduces the fuel when the speed reaches the idle speed setting. The max fuel limit limits the travel of the rack after the engine speed is above the idle speed. (The max fuel limit is generally set 2% to 5% above the actuator output for full load). The torque limiter limits the maximum fuel position proportional to the actual engine speed.

Auxiliary Input

The ProAct II control uses the auxiliary input to interface with loadsharing equipment.

RUN/STOP Switch

The “RUN/STOP” switch allows the user to shutdown the actuator to 0% position at any time.

Failsafe Override

The failsafe function prevents possible overspeed should the MPU signal be lost for any reason during normal engine operation.

Alternate Dynamics Switch

When you set the “ALTERNATE DYNAMICS” switch, you select the alternate fuel conditions.

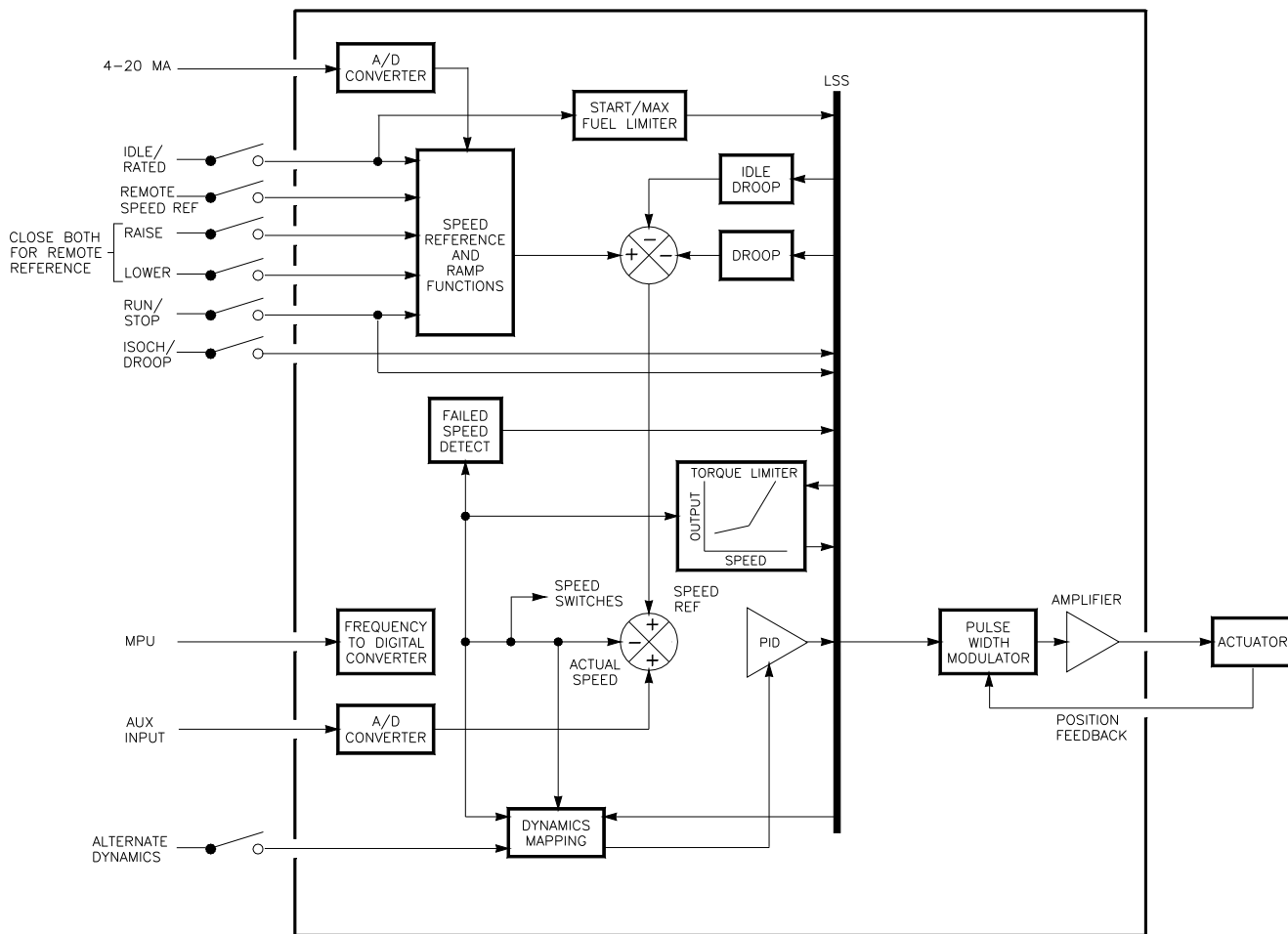

Figure 1. Block Diagram ProAct II System

Menus

This section gives an explanation of all the parameters in the seven menus. For how to get access to these menus, see Figure 13. When you start to program these menus, start with menu 6, followed in order by menus 3, 4, 0, 5, 1, and 2.

Menu 6—Configuration Menu

When you program the parameters in the configuration menu, you have to push the “6” key on the handheld programmer. The display shows one of the following parameters:

1 Configuration key

Configuration Key is the code you have to enter before you can change the set points. The configuration key prevents any accidental modification of the set points and is factory set at “49”. Before you change this menu, the engine must be at 0 rpm and the Run/Stop switch should be in the open position.

2 Number of Gear Teeth

The Number of Gear Teeth is the number of teeth on the gear or flywheel that drives the speed sensing device.

3 Dynamics Map

Dynamics Map selects the mapping algorithm used to map dynamics as a function of engine speed.

4 Failsafe Function

The failsafe function must be enabled during normal engine operation.

Menu 6 Settings

Parameter	Default Setting	Range Setting	Final Setting
Configuration Key	0	0–100	
Number of Gear Teeth	60	4–500	
Dynamics Map	Linear	Linear/Nonlinear	
Failsafe Function	Enabled	Disabled/Enabled	

Menu 3—Speed Reference Menu

When you program the parameters in the speed reference menu, you have to push the “3” key on the handheld programmer. The display shows one of the following parameters:

1 Rated Speed

Rated Speed is the normal operating speed of the engine.

2 Idle Speed

Idle Speed is the speed at which the engine operates during start-up, and sometimes during cool down.

3 Raise Limit

Raise Limit is the maximum speed setting to limit the Raise Speed command and the Remote Reference to a maximum. The Raise Limit has normally the same setting as the rated speed.

4 Lower Limit

Lower Limit is the minimum speed setting to limit the Lower Speed command and the Remote Reference to a minimum.

5 Accel Time

Accel Time is the time for the control to ramp the speed setpoint from idle speed to rated speed. The ramp starts when you close the “IDLE/RATED” switch.

6 Decel Time

Decel Time is the time for the control to ramp the speed setpoint from rated speed to idle speed. The ramp starts when you open the “IDLE/RATED” switch.

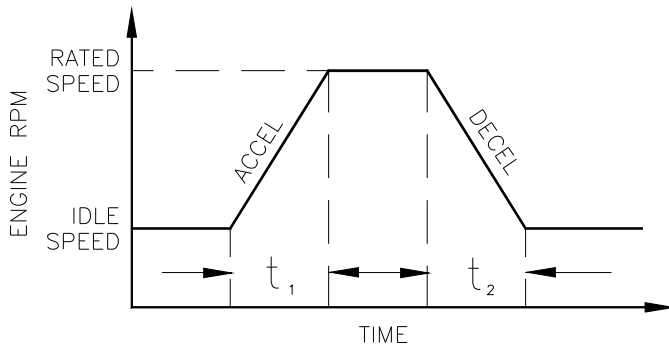

t =IDLE/RATED RAMP TIME (seconds)
 t_1 =Accel Time t_2 =Decel Time

Figure 2. Accel/Decel Time

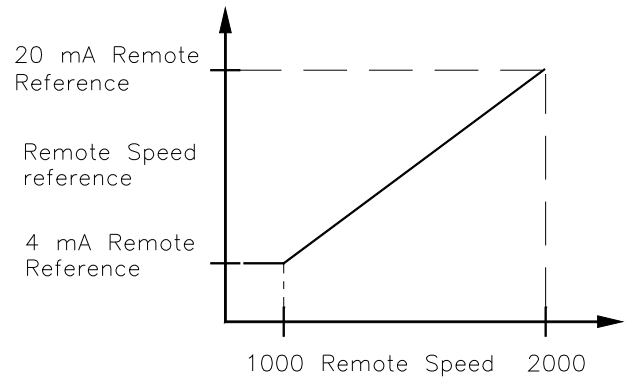

Figure 3. Remote Speed Reference

7 Raise Rate

Raise Rate is the rate at which the speed reference ramps to the raise rate, when you close the “RAISE” switch, or when the Remote Speed Setting changes in the increased direction.

8 Lower Rate

Lower Rate is the rate at which the speed reference ramps to the lower rate, when you close the “LOWER” switch, or when the Remote Speed Setting changes in the decreased direction.

9 4 mA or 20 mA Remote Reference

4 mA or 20 mA Remote Reference is the speed setpoint when 4 or 20 mA is applied to the Remote Speed Reference input.

10 Droop

Droop is set as the percent rated speed will be decreased from no load to full load. Droop is included when you hold the “ISOCH/DROOP” switch in the open position. The droop percentage is based on 75° actuator travel. When the actuator travel is less than full actuator travel, the droop percentage should be increased proportionally.

11 Idle Droop

Idle Droop in combination with the Idle Droop Breakpoint limits the speed undershoot, when you use large deceleration rates from rated to idle.

12 Idle Droop Breakpoint

Idle Droop Breakpoint is set equal to the actuator output, when the engine is unloaded and at idle. When the output of the control drops below this setting, or goes to minimum fuel during rapid engine deceleration, the Idle Droop as described above raises the speed reference.

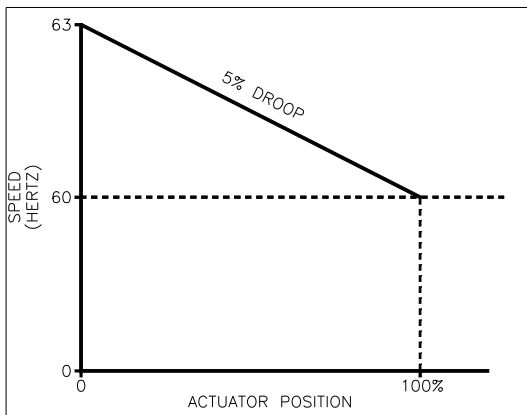

Figure 4. Droop Curve

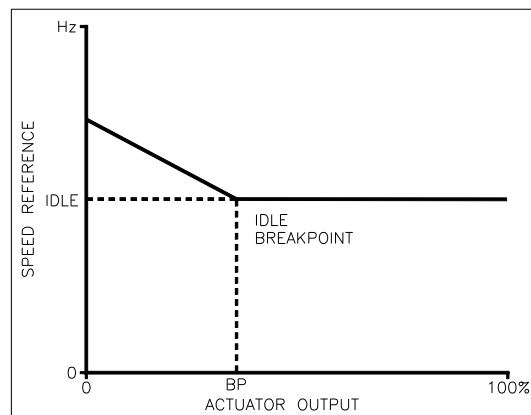

Figure 5. Idle Droop

13 Speed Switches A/B/C

Speed Switches A/B/C On, set the speed reference to turn on the Speed Switches. Speed Switches A/B/C Off, set the speed reference to turn off the Speed Switches.

Menu 3 Settings

Parameter	Default Setting	Range Setting	Final Setting	Units
Rated Speed	1800	0–2100		rpm
Idle Speed	1200	0–2100		rpm
Raise Limit	2100	0–2100		rpm
Lower Limit	1200	0–2100		rpm
Accel Time	3	0–500		seconds
Decel Time	3	0–500		seconds
Raise Rate	2500	0–9999		rpm/min
Lower Rate	2500	0–9999		rpm/min
20 mA Remote Ref	1890	0–2100		rpm
4 mA Remote Ref	1710	0–2100		rpm
Droop	0	0–100		%
Idle Droop	0	0–100		%
Idle Droop BP	0	0–100		%
Speed Switch A On	600	0–2100		rpm
Speed Switch A Off	540	0–2100		rpm
Speed Switch B On	1200	0–2100		rpm
Speed Switch B Off	1140	0–2100		rpm
Speed Switch C On	2000	0–2100		rpm
Speed Switch C Off	1900	0–2100		rpm

Menu 4—Fuel Limits Menu

When you program the parameters in the fuel limiter menu, you have to push the “4” key on the handheld programmer. The display shows one of the following parameters:

- 1 Maximum Fuel Limit**
Maximum Fuel Limit limits the actuator output when you select rated speed.
- 2 Transient Limit**
Transient Limit allows overfueling the engine by the amount tuned into the control, when the maximum fuel limit controls the output power of the engine.
- 3 Transient Time**
Transient Time is the time that the transient limit is allowed to operate.
- 4 Start Fuel Limit**
Start Fuel Limit limits the engine during starting, to reduce smoke on diesel engines and to prevent overfueling during the start of gas engines.

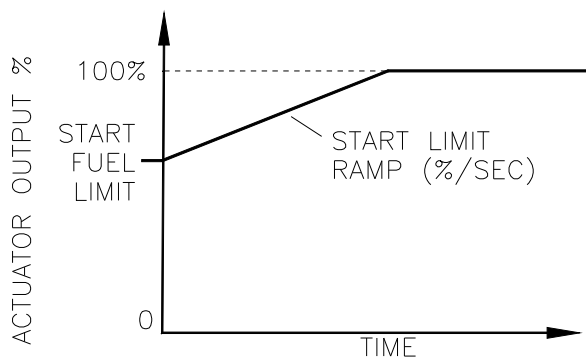

Figure 6. Start Fuel Limit

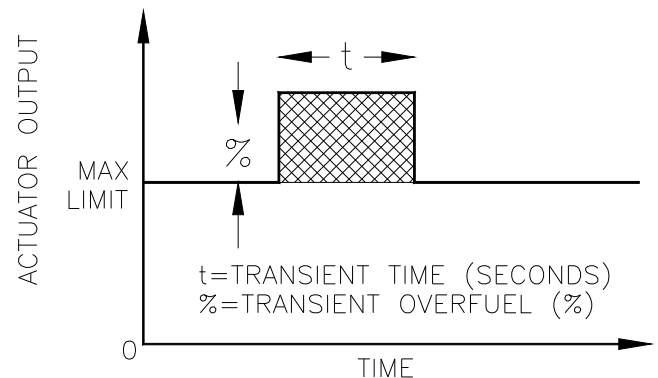

Figure 7. Transient Overfuel

5 Start Ramp

Start Ramp is a tunable ramp for the actuator output to ensure the start of cold engines. The control ramps the position of the actuator from the start fuel limit open at a controlled rate until the engine starts.

6 Start Speed

Start Speed is the speed that removes the start fuel limit from the control system.

7 Minimum Torque Limit

Minimum torque Limit limits the actuator output when the engine speed is below or at the lower limit speed setting (Menu 3).

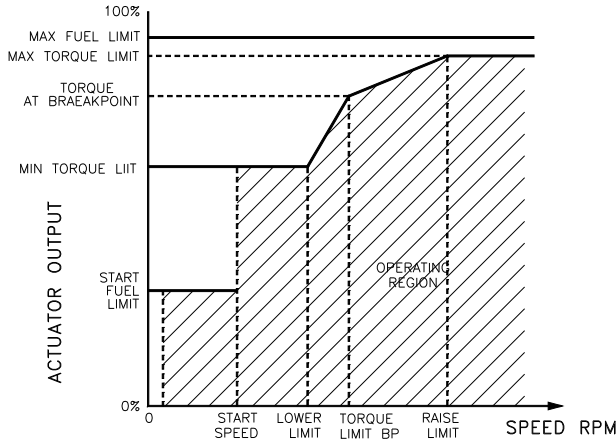

Figure 8. Torque Limit Map

8 Torque Limit Breakpoint (BP)

Torque Limit BP is the engine speed at which the slope of the torque limiter output changes.

9 Torque Limit at BP

Torque Limit at BP is the percentage actuator output from the Torque Limit Breakpoint.

10 Maximum Torque Limit

Maximum Torque Limit limits the actuator output when the engine speed is at the Raise Limit speed setting.

Menu 4 Settings

Parameter	Default Setting	Range Setting	Final Setting	Units
Max Fuel Limit	100	0-100		%
Transient Over Fuel	100	0-100		%
Transient Time	0	0-10		sec
Start Fuel Limit	40	0-100		%
Start Ramp Rate	0	0-20		%/sec
Start Speed	100	0-1200		rpm
Min Torque Limit	0	0-100		%
Torque Limit BP	1500	0-2100		rpm
Torque Limit at BP	50	0-100		%
Max Torque Limit	90	0-100		%

Menu 0—Error Menu

When you program the parameters in the error menu, you have to push the “0” key on the handheld programmer. The display shows one of the following parameters:

- 1 **Active Errors**
Active Error display shows the errors that the control detects and are still present. You have to clear these errors with the “RUN/STOP” switch, before you start the engine.
- 2 **Logged Errors**
Logged Errors record the errors which the control detects. The control saves the logged error, even if the power to the control is lost. To clear the logged error, push the “■” key on the handheld programmer.
- 3 **Self Test Result**
Self Test Result display shows “49” when the test is successful.

Menu 0 Settings

Parameter	Default setting	Range Setting	Final Setting
Active Errors	None	N/A	N/A
Logged Errors	None	N/A	N/A
Self Test Result	*49	N/A	N/A

Menu 5—Display Menu

The display menu shows the input and output values of the ProAct II system, when you push the “5” key on the handheld programmer. The display shows one of the following input or output values:

- 1 **Speed**
Speed display shows the current engine speed.
- 2 **Speed Reference**
Speed Reference display shows the current speed reference.
- 3 **Actuator Output**
Actuator Output display shows the current actuator output.
- 4 **Aux Input**
Aux Input display shows the voltage on the Aux Input.
- 5 **Remote Input**
Remote Input display shows the current on the Remote Input.
- 6 **Actuator Current**
Actuator Current display gives a readout of the current to the actuator.
- 7 **Actuator Position**
Actuator Position display gives a readout of the voltage from the position feedback.
- 8 **Run/Stop Switch**
Run/Stop Switch display shows the status (Open/Closed) of the discrete input at terminal 23. Closed indicates the run position.
- 9 **Idle/Rated Switch**
Idle/Rated Switch display shows the status (Open/Closed) of the discrete input at terminal 17. Closed indicates the idle position.
- 10 **Raise Switch**
Raise switch display shows the status (Open/Closed) of the discrete input at terminal 19. Closed indicates the raise speed position or the remote speed setting when the lower switch is also closed.
- 11 **Lower Switch**
Lower switch display shows the status (Open/Closed) of the discrete input at terminal 18. Closed indicates the lower speed position or the remote speed setting when the raise switch is also closed.

12 Alternate Dynamics Switch

Alternate Dynamics Switch display shows the status (Open/Closed) of the discrete input at terminal 20. Closed indicates the Alternate Dynamics position.

13 Remote Reference Switch

Remote Reference Switch display shows the status (Open/Closed) of the discrete input at terminal 21. Closed enables the remote speed setting at terminals 14 and 15, and disables the raise and lower switches.

14 Droop

Droop display shows the status (Open/Closed) of the discrete input at terminal 16. Open indicates droop and Closed indicates isochronous.

IMPORTANT

When you close one of the switches mentioned above, 24 Vdc is applied.

15 Speed Switches A/B/C

Speed Switches A/B/C indicate the On/Off position of the switches.

Menu 1—Dynamics Menu

When you program the parameters in the dynamics menu, you have to push the “1” key on the handheld programmer. The display shows one of the following parameters:

1 Gain settings and Gain breakpoint settings

The four gain settings and gain breakpoint settings determine the actuator response to a change in speed or load. These gain settings can vary as a percentage of existing load in nonlinear fuel systems, and affect the stability and transient performance of the engine. A large number of gain settings provide a faster response to an error between the actual speed and the reference speed. How to control the gain program, see the Gain Programming Control section below.

The butterfly valve change in a gas engine is not linear to the engine output (Figure 9). Diesel engine fuel controls are nearly linear (Figure 10). In this case, you use the dynamics map only to accommodate non linear conditions caused by the fuel system or by the linkage between the actuator and the rack. For the gain settings you do not use, set the gain breakpoint at 100%.

IMPORTANT

In Figure 10, the valve position falls on a curve, but with the four slope segments you can create a rough expression of the curve, see Figure 12.

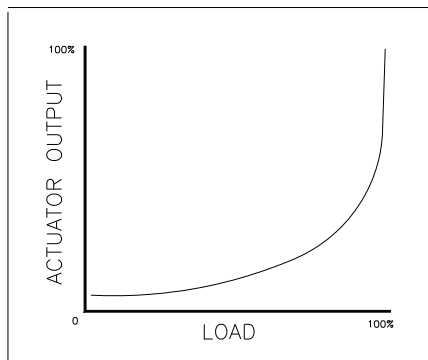

Figure 9. Non-Linear Valve Power

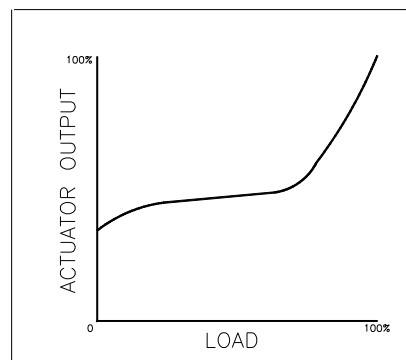

Figure 10. Sample Engine Plot

2 Stability

Stability compensates for the time delay of the engine. It adjusts the time for the control to return the speed to the actual speed after a disturbance. Stability adjustment prevents slow hunting and minimizes speed overshoots after a load disturbance.

3 Compensation

Compensation compensates for the actuator and fuel system time constant.

4 Gain Ratio

Gain Ratio operates in combination with the Window Width and the Gain adjustments. The control multiplies the Gain setpoint by the Gain Ratio, when the speed error is higher than the Window Width. This multiplication makes the control dynamics fast enough to minimize the engine speed overshoot on start-up and to reduce the value of the speed error when the load changes. It allows also a lower gain for better stability and reduced actuator movement.

5 Window Width

Window Width is the value of the speed error at which the control switches to fast response. The control does not use the value of the speed error, but an "anticipated" speed error to provide smoother switching. The Window Width gives a high gain value when an off speed occurs, and a low gain value when recovering from the speed transient.

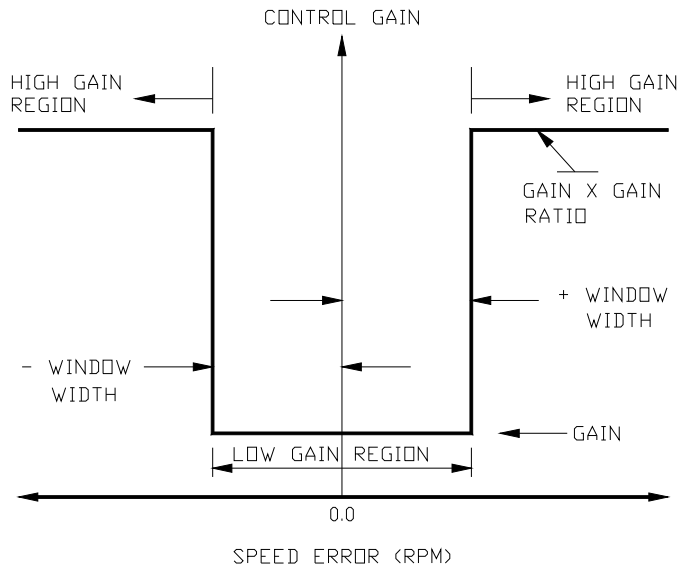

Figure 11. Window Width for Gain Ratio

Menu 1 Settings

Parameter	Default Setting	Range Setting	Final Setting	Units
Gain A	0.025	0.0003–10.00		–
Gain A BP	25	0.00–100.00		%
Gain B	0.025	0.0003–10.00		–
Gain B BP	50	0.00–100.00		%
Gain C	0.025	0.0003–10.00		–
Gain C BP	100	0.00–100.00		%
Gain D	0.025	0.0003–10.00		–
Gain D BP	100	0.00–100.00		%
Stability	1.0	0.00–10.00		seconds
Compensation	0.15	0.00–10.00		seconds
Gain Ratio	1.0	1.00–50.00		–
Window Width	60	0.00–2000.00		rpm

Menu 2—Alternate Dynamics Menu

Menu 2 provides a second set of dynamics for use with an alternate fuel condition which requires different control factors. You select the “Alternate Dynamics” with the Alternate Dynamics switch. If the engine does not use the alternate conditions, then do not program menu 2 or program menu 2 the same as menu 1.

Gain Programming Control

You have to program the gain in menu 1, whenever the engine or fuel system is non-linear. Determine a plot of the fuel system to adjust the gain of the ProAct II speed control at all loads. Construct a gain plot according to these steps:

1. Set the Gain A break point at 100%.
2. Start the engine without load and obtain good control with the use of Gain A, Stability, and Compensation. Write down these settings together with the actuator output in menu 5.

LOAD STEP	GAIN for good control	ACTUATOR OUTPUT
1.		
2.		
3.		
4.		
5.		
6.		
7.		
8.		
9.		
10.		

- 3 Load the engine with a number of load steps as practical. If necessary adjust the engine stability at each load step with Gain A. Write the engine load settings, gain A, and the actuator output in the given table. Do not change the stability or compensation after the first load step. If you do repeat step (2).
- 4 Make a plot of the system with the actuator output and the load steps as listed in the table. See example of a plot in Figure 10.
- 5 Set Gain A to the value in step (2) with no load.
- 6 Use the plot of the engine to determine the linearity of the fuel system as shown in Figure 12.
- 7 Set the Gain Breakpoints, according to Figure 12:
 - Gain A Breakpoint slightly below the first inflection point
 - Gain B Breakpoint slightly above the first inflection point
 - Gain C Breakpoint slightly below the second inflection point
 - Gain D Breakpoint higher than the second inflection point.

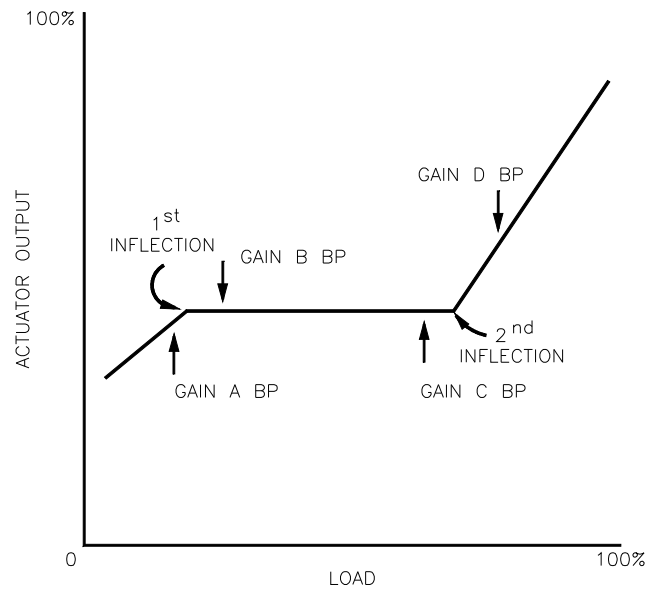
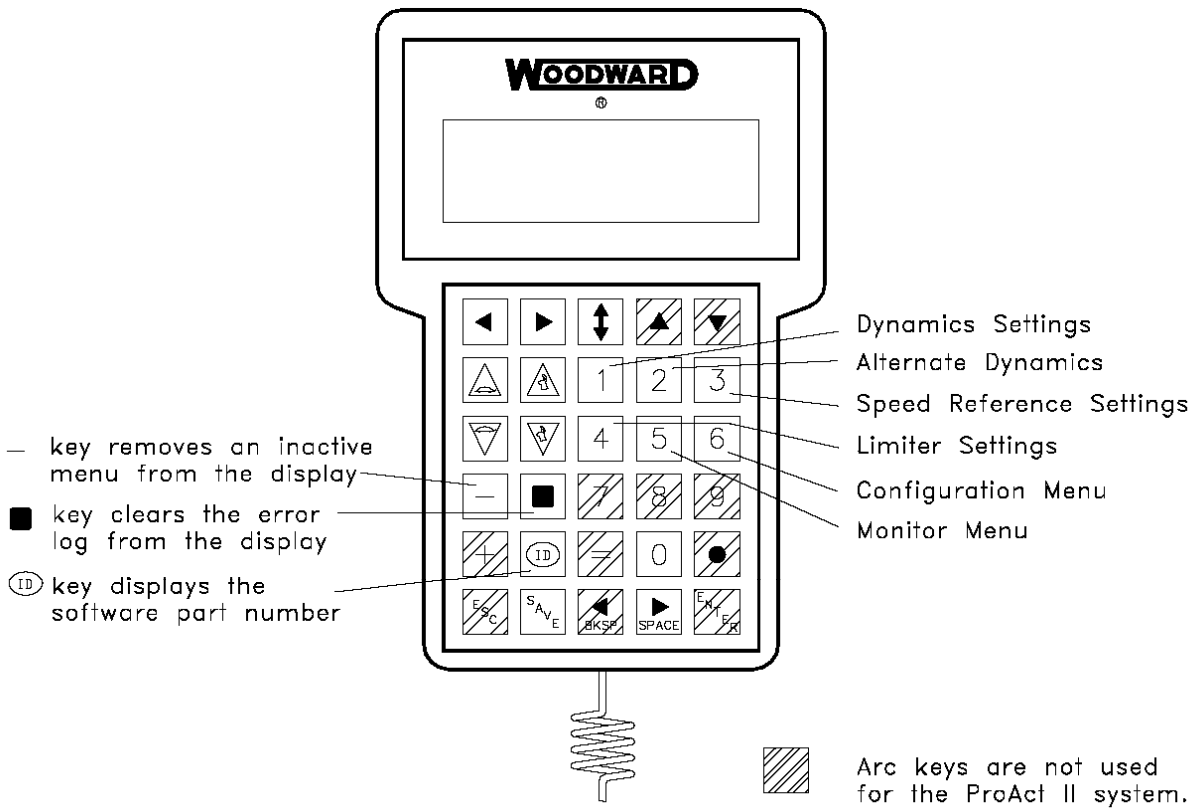

Figure 12. Linearized Engine Plot

- 8 If necessary, do the same settings for Gain B, Gain C and Gain D as mentioned in step (3).



Example 1: Parameter setpoint change

Example 2: Toggle between two menus

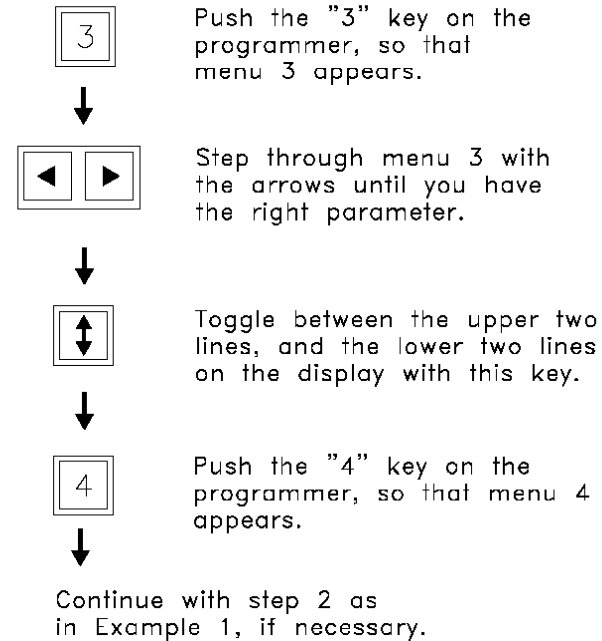
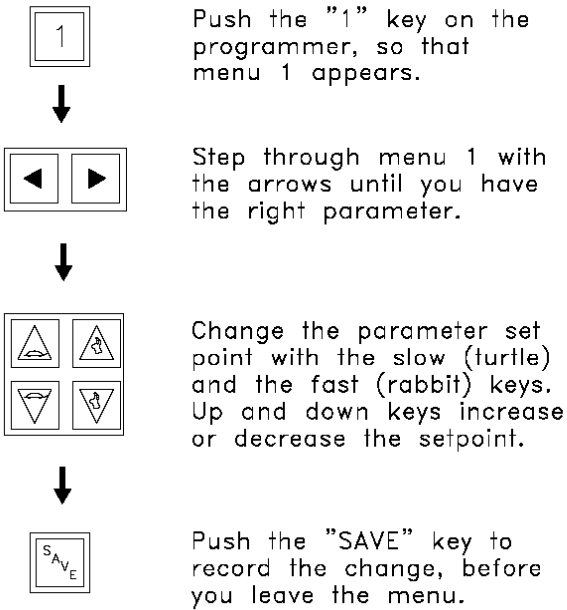

Figure 13. Handheld Programmer

We appreciate your comments about the content of our publications.

Send comments to: icinfo@woodward.com

Please reference publication **36060**.



PO Box 1519, Fort Collins CO 80522-1519, USA
1000 East Drake Road, Fort Collins CO 80525, USA
Phone +1 (970) 482-5811 • Fax +1 (970) 498-3058

Email and Website—www.woodward.com

**Woodward has company-owned plants, subsidiaries, and branches,
as well as authorized distributors and other authorized service and sales facilities throughout the world.**

Complete address / phone / fax / email information for all locations is available on our website.