



WIP1- Self powered time overcurrent relay

(November 2007)

Manual WIP1 (Revision New)

Woodward Governor Company reserves the right to update any portion of this publication at any time. Information provided by Woodward Governor Company is believed to be correct and reliable. However, no responsibility is assumed by Woodward Governor Company unless otherwise expressly undertaken.

© Woodward 1994-2008

Contents

1. General	5
2. Characteristics and Features	6
3. Design	7
3.1 Connections	7
3.1.1 Connecting the serial Interface	11
3.1.2 Analog inputs	12
3.1.3 Control inputs	12
3.1.4 Operation outputs	13
3.1.5 Battery	14
3.1.6 Trip indication	14
3.1.7 Serial Interface	14
4. Working Principle	15
4.1 Analog circuits	15
4.2 Digital circuits	15
4.3 Battery buffer	16
4.3.1 Additional power part	16
4.3.2 Transformer Power Supply	16
4.3.3 Important note for the battery function	16
4.4 Indicating and operating elements	17
4.4.1 Front plate	17
4.4.2 Display	17
4.4.3 LED	17
4.5 Function push buttons	17
4.6 Opening the front cover	18
4.7 Requirements for the main C.T.s	19
4.7.1 Determining the maximum coil resistance	19
4.7.2 Characteristics of the current transformers	20
4.7.3 Overloading of the WIP1	22
4.7.4 Dimensioning example	23
5. Operations and settings	25
5.1 Function of push buttons	26
5.1.1 Measuring value and fault indication	26
5.1.2 Display	27
5.1.3 Setting procedure	27
5.1.4 Parameter setting by using the password	27
5.2 Display of measuring values	28
5.3 Displaying the pickup phase	29
5.4 Display of tripping values	29
5.5 Protection parameters	31
5.5.1 Pickup value for phase overcurrent element	31
5.5.2 Time current characteristics for phase overcurrent element	31
5.5.3 Trip delay or time multiplier for phase overcurrent element	31
5.5.4 Reset mode for inverse time tripping characteristics for phase overcurrent element ..	32
5.5.5 Minimal time	32
5.5.6 Current setting for high set element	32
5.5.7 Trip delay for high set element	32
5.5.8 Pickup value for earth fault current element	33
5.5.9 Tripping characteristic for earth fault current element	33
5.5.10 Trip delay or time multiplier for earth fault overcurrent element	33
5.5.11 Reset mode for normal inverse time tripping characteristics for earth fault element	33
5.5.12 Minimum tripping time (earth fault element)	33
5.5.13 Current setting for earth fault high set element	33
5.5.14 Trip delay for earth fault high set element	33
5.6 System parameters	34
5.6.1 Selection of the language	34
5.6.2 Password programming	34
5.6.3 Date setting	35

5.6.4	Time setting	35
5.6.5	Rated frequency setting	35
5.6.6	Adjustment of the slave address (WIP1-3)	35
5.6.7	Baud Rate setting (W11-3)	35
5.6.8	Setting of parity	36
5.6.9	Indication of the software version	36
5.7	Tripping method/Relay matrix	36
5.7.1	Reset	36
5.7.2	Tripping method	36
5.7.3	Earth fault overcurrent	37
5.7.4	Flashing of the Trip-LED	37
5.7.5	Relay matrix (only relay 2)	37
5.8	Signal inputs	38
5.8.1	Fast trip	38
5.8.2	Blocking the protection functions	38
5.9	Reset	38
5.10	Clearing the fault memory	39
6.	Relay testing and commissioning	40
6.1	Checking the set values	40
6.2	Secondary injection test	40
6.2.1	Test equipment	40
6.2.2	Example of test circuit	41
6.2.3	Checking the tripping circuits	42
6.2.4	Checking the input circuits and measured values	44
6.2.5	Checking the overcurrent element	44
6.2.6	Checking the high set element of the relay	44
6.2.7	Checking the external blocking	45
6.2.8	Checking the input "Fast trip"	45
6.2.9	Remote trip	45
6.2.10	Test of input „External Reset“	45
6.2.11	Checking the battery	45
6.2.12	Loss of information due to non-existent or empty battery	46
6.3	Primary injection test	47
6.4	Maintenance	47
7.	Technical data	48
7.1	System data	50
7.2	Setting ranges and steps	51
7.3	Inverse time tripping characteristics	52
7.3.1	Tripping characteristics	54
7.4	Relay case	61
7.5	Flag indicators	62
8.	Order form	64

1. General

The WIP1 is a self powered time overcurrent relay with multi-characteristics. Definite time and inverse time trip-ping characteristics can be selected. The WIP1-1 does not require any aux. voltage supply, consequently it can also be used for switchboards without built-in batteries. It takes its power supply energy from the C.T. circuits and provides the tripping pulse energy to the circuit breaker. Due to its wide setting ranges, the tripping characteristic can be selected to protect a wide variety of different equipment.

Optionally the WIP1 is available with earth fault element (option IE) and negative sequence element (option I_S). The relay is buffered by a battery for feeding the LC display as well as for memorizing fault values and reset of the trip relay. Failure of the battery has no effect on the protective functions of the relay. The battery has a service life of more than 10 years.

2. Characteristics and Features

- Auxiliary voltage supply is not required
- User-friendly setting procedure with wide setting ranges
- Digital filtering of measured quantities by using discrete Fourier analysis to suppress high frequency harmonics and transient DC components induced by faults or system operations
- Two-element overcurrent and short circuit relay
- Selectable protection functions between:
 - definite time overcurrent and
 - inverse time overcurrent
- Selectable inverse time characteristics acc. to IEC 255-4:
 - normal inverse (type A)
 - very inverse (type B)
 - extremely inverse (type C)
 - special characteristics
- Reset mode for inverse time characteristics selectable
- High-set overcurrent element with instantaneous or definite time function
- Two-stage earth fault supervision (Option IE) with tripping and/or alarm function
- Two-stage load unbalance supervision (Option IS)
- Redundant power supply unit for external voltage supply (Option WIP1-2)
- Serial interface for connection to SCADA Systems (Option WIP1-3)
- Phase and earth current measuring during normal operation
- Five fault memories
- High-accuracy components and over-rating guarantee precision, reliability and a long service life
- High operating reliability through internal self-supervision (watchdog); internal faults are indicated by an alarm relay
- Remote tripping via external voltage
- High-capacity electric pulse output for direct triggering the circuit breaker
- Trip indication via external flag indicator with mechanical reset
- Two potential free alarm contacts, latched type (bi-stable relay)
- Relay with one potential free contact; tripping function selectable
- Trip value indication via LCD display, battery-buffered
- Compact construction
- Insensitive to extreme environmental conditions
- In accordance with the specified technical data, it complies with the requirement of VDE regulation 0435-303, IEC255, VDE 0843

3. Design

3.1 Connections

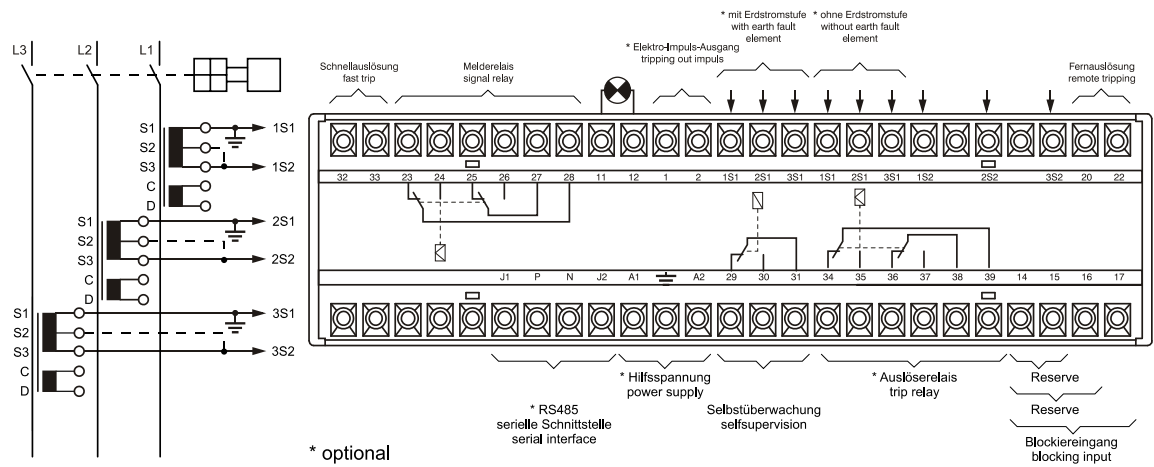

Figure 3.1: Connection example with relay tripping

Important Information!

It is essential that the WIP1 is earthed via terminal .

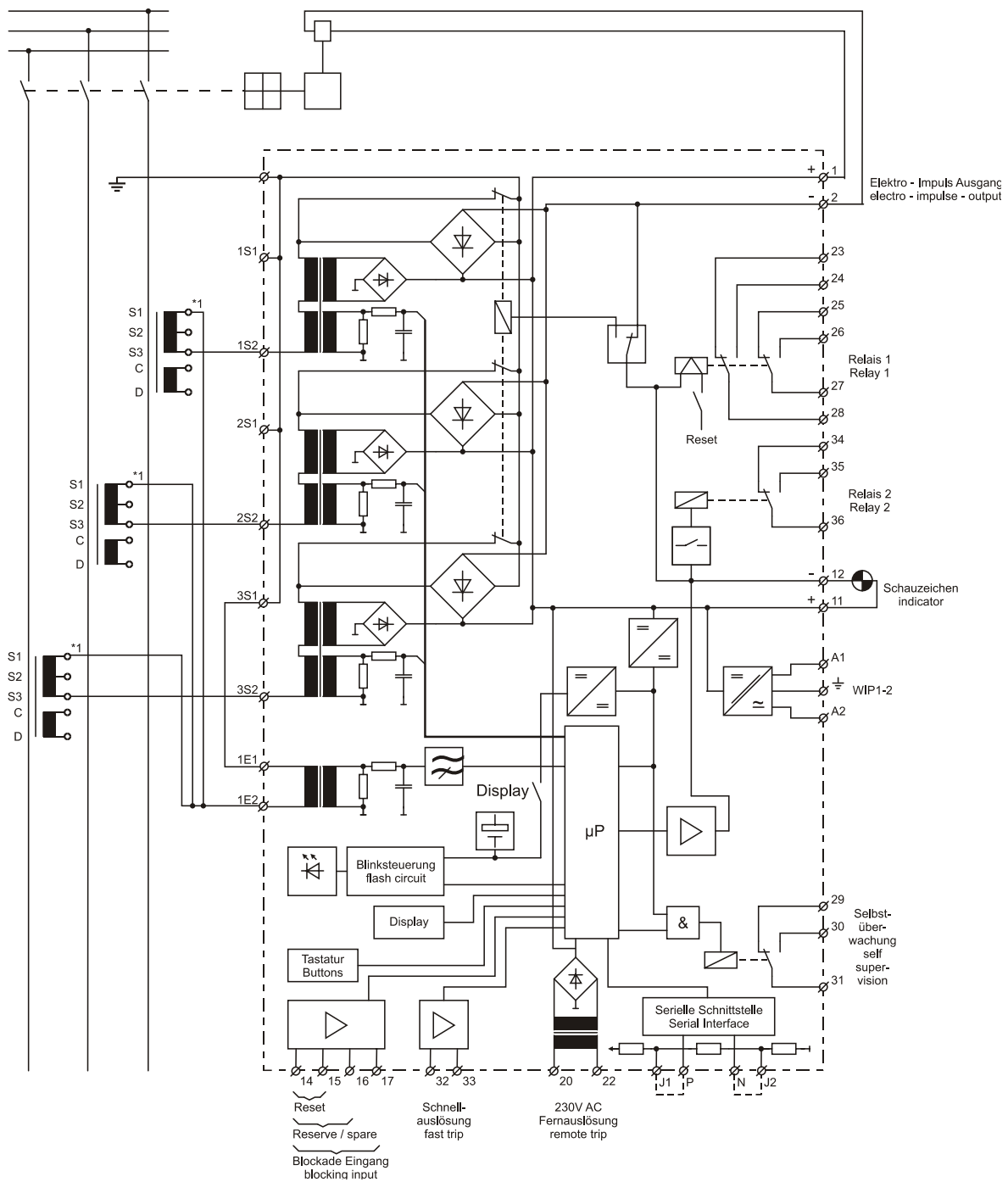

Figure 3.2: Block diagram

Please note!

In this circuit we recommend earthing the current transformers via the relay connection. *1: If the current transformers have to be earthed directly, the earthing connection on WIP1 must be removed. Otherwise the measuring transformer for earth fault measuring is short circuited.

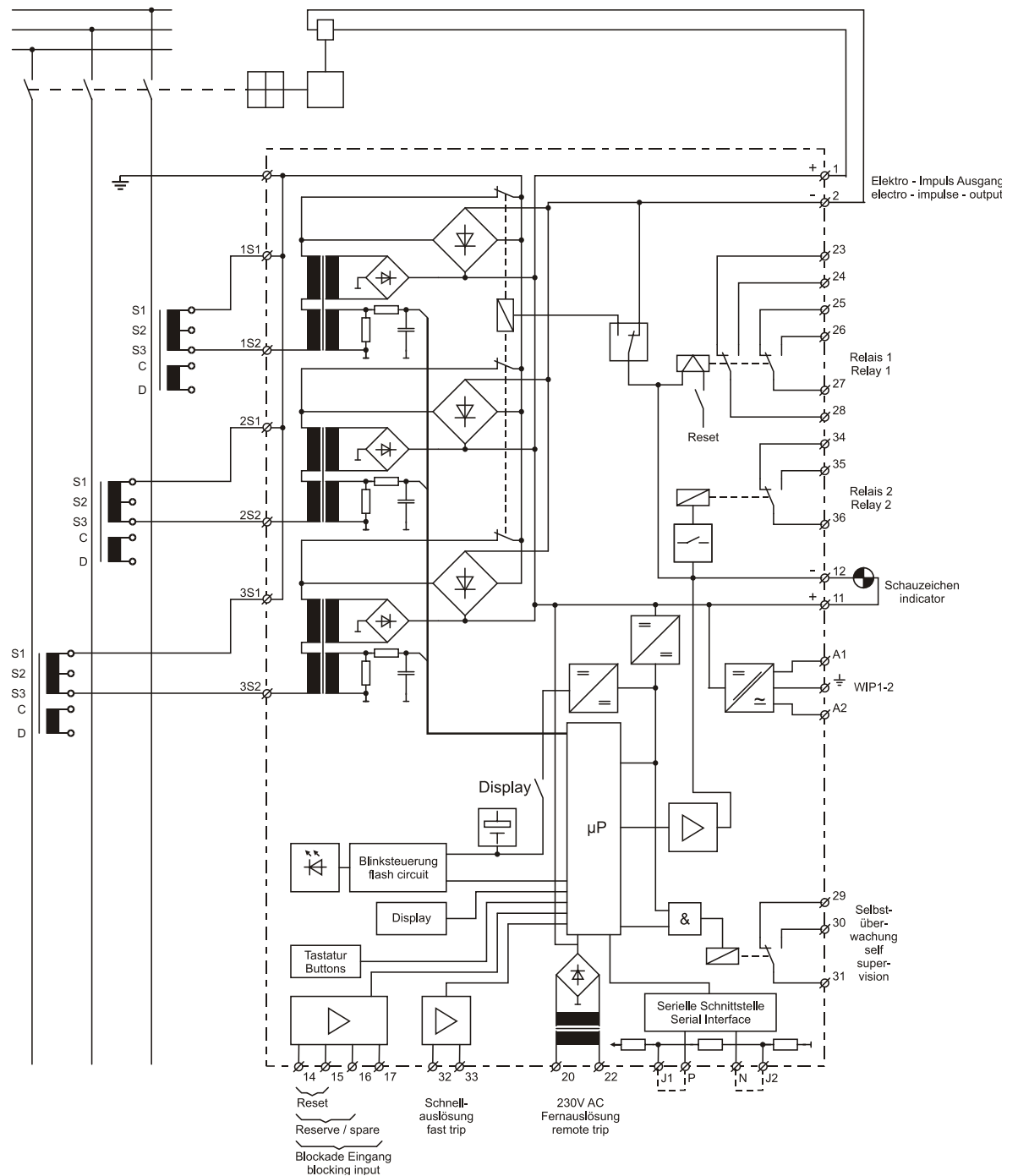

Figure 3.3: Block diagram WIP1-11 (only phase current measuring)

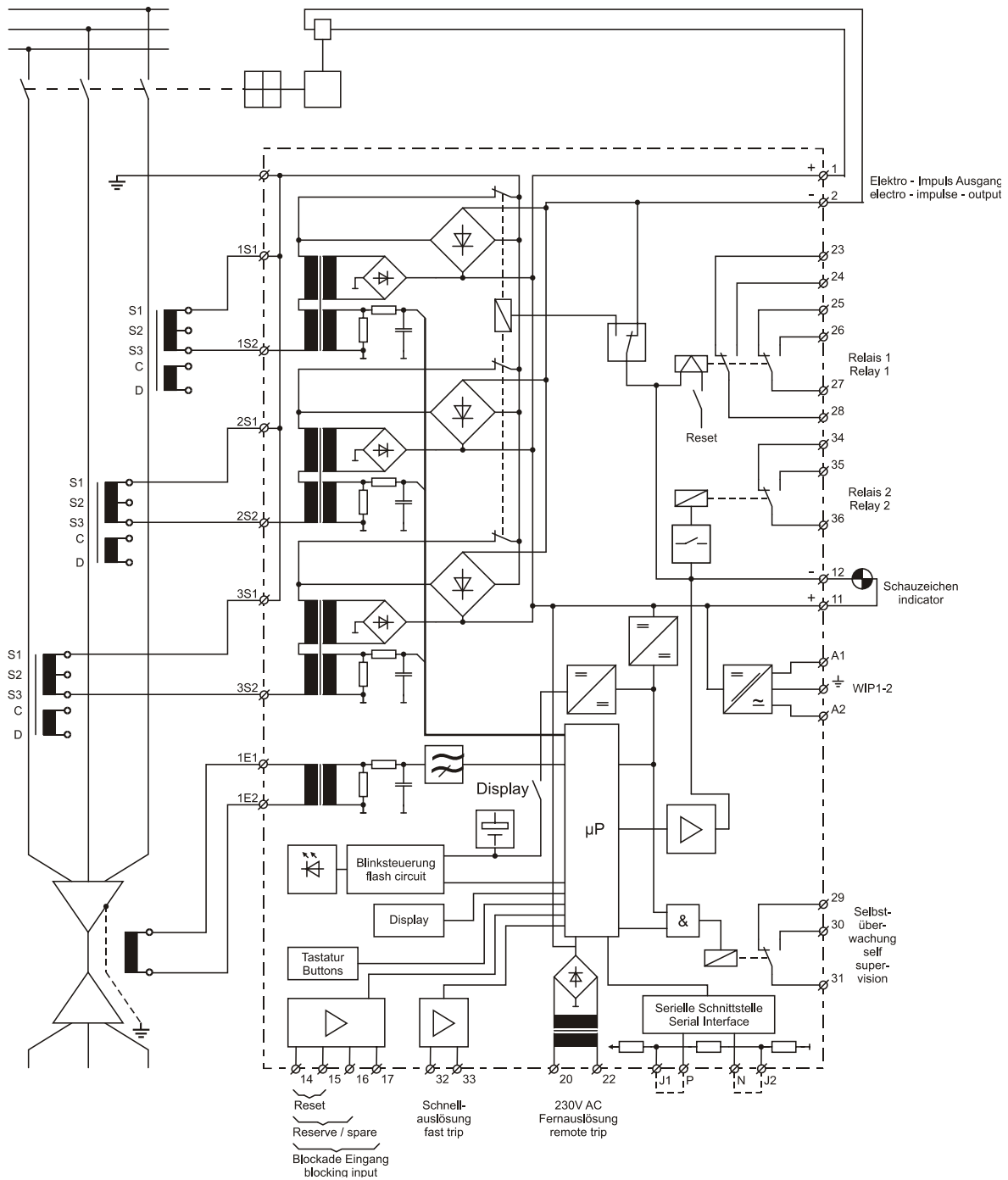

Figure 3.4: Block diagram WIP1-I1-E1 with earth fault detection via C.T. cable type

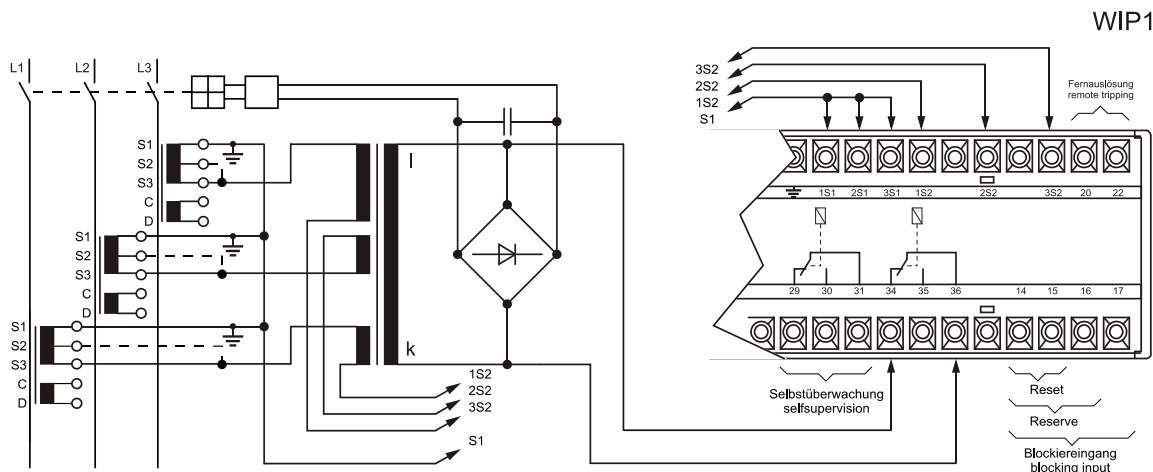

Figure 3.5: Connection example with relay tripping

3.1.1 Connecting the serial Interface

The relays are connected to a PC/laptop via an RS232/RS485-interface converter by using the two-wire method. Each relay is connected to terminals P and N. The last relay in terms of »hardware« must then be equipped with terminating resistors. This is done by connecting terminals P with J1 and N with J2.

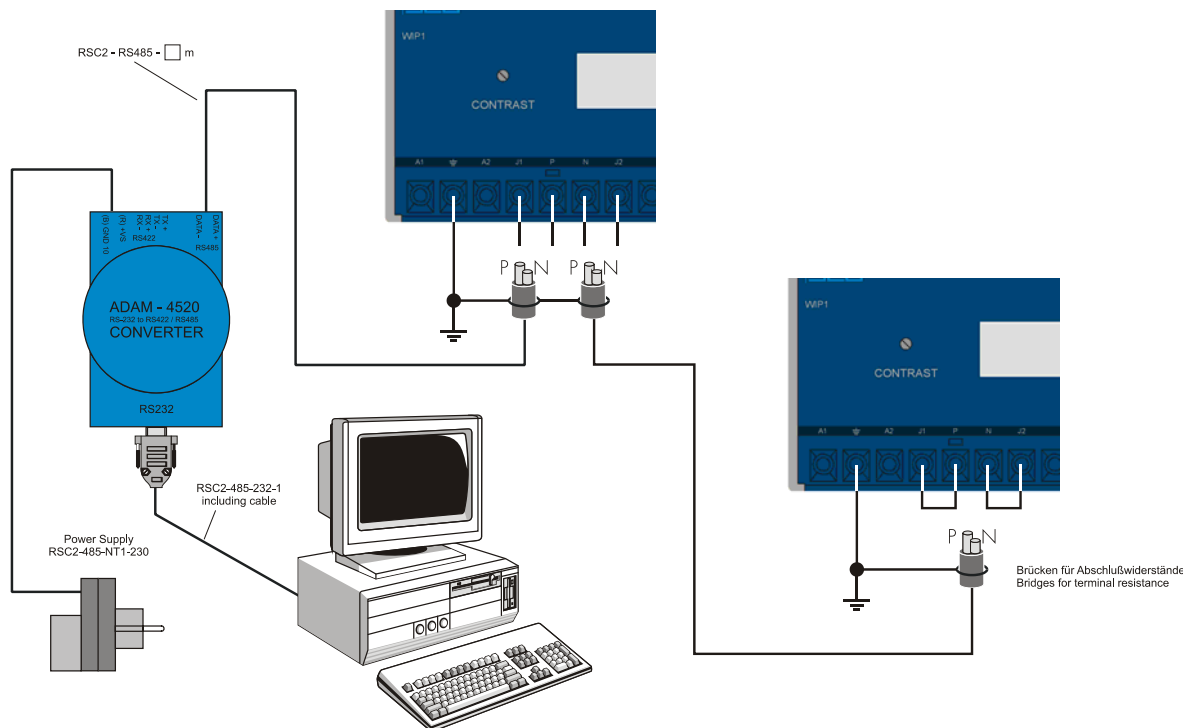

Figure 3.6: Connection of the serial interface

3.1.2 Analog inputs

The protection unit WIP1 receives the analog input signals of the phase currents I_{L1} (1S1 - 1S2), I_{L2} (2S1 - 2S2) and I_{L3} (3S1 - 3S2) for phase current, earth current and negative sequence measuring. The measured current values are analogously filtered and fed to the analog/digital converter.

3.1.3 Control inputs

Input remote tripping

The remote tripping input (terminals 20 and 22) enables tripping by an external voltage pulse, e.g. from a thermal overcurrent tripping device, Buchholz protection or other external trip commands. By bypassing the measuring circuits, this input (230 V AC max. 5 min) has a direct effect on the trip circuit. The input terminals are galvanically decoupled from the relay electronics.

Signal inputs

Signal inputs for blocking and protection (terminals 14 and 17) for fast trip (terminals 32 and 33) as well as external reset (terminals 14 and 15) can be activated by applying an external voltage.

Blocking function (terminals 14 and 17):

Single or all trip elements can either be blocked or re-leased.

Fast trip (terminals 32 and 33):

By this function the CB can be tripped instantaneously. There are two different kind of trippings:

Instantaneous means, a trip is initiated as soon as the minimum current is available (lowest power supply value adjustable).

After activation means, the high-speed tripping function only is activated if one of the phase currents exceeds the set value.

The fast trip input can be applied for e.g. arcing fault detectors.

Reset

After a trip event the alarm relay is reset and the LED extinguishes when voltage is applied (see also chapter 5.9).

3.1.4 Operation outputs

There is the choice of two tripping methods:

- **Electric pulse output**

As trip commands the WIP1 gives power pulses direct to the tripping coil of the CB (terminals 1 and 2). These pulses are given every 250 ms and repeated until the CB is switched off.

- **Potential free contacts (relay 1/latching) terminals (23, 24, 28 and 24, 25, 26)**

For applications where a higher trip output energy is required, a bi-stable relay with two potential free changeover contacts is provided in the trip circuit. After the relay has tripped, the contacts remain in trip position until reset by the <RESET> push button.

- **Potential free contacts (relay 2) terminals (34, 35, 36)**

For applications where a higher trip output energy is required, a relay with one potential free changeover contact is provided in the trip circuit. This Relay can be assigned to any function (see 5.7).

Example:

When using DC coils it has been observed that the breaking capacity of the output contacts is not unlimited (see chapter 7).

In case the coil burden is higher than the contact breaking capacity, the following circuit arrangement can be used:

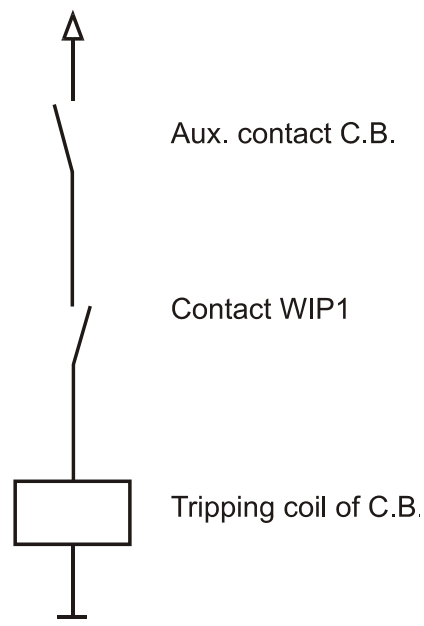

Figure 3.7: Example

- By connecting a trip contact of the WIP1 and an aux. contact of the C.B. in series it is prevented that the WIP1 contact is arcing so that safe switching off is guaranteed.
- Watchdog (Terminals 29, 30, 31) For continuous supervision of the program flow a "hardware watchdog" is installed. In case of processor failure, the watchdog is activated after detection of a specific minimal current. The self supervision relay is a working current relay.

3.1.5 Battery

The WIP1 relay is provided with a lithium battery for maintaining the clock function and to allow setting and read out without external power supply. The fault memory and parameters can be read-out or changed. The battery is housed underneath the front cover of the relay at the lower right corner and is fastened by plug terminals, simplifying replacement of the battery.

3.1.6 Trip indication

The WIP1 is provided with an LED for the optical trip indication. Tripping can additionally be indicated via an external indicator. Flashing of the LED can be suppressed by parameter setting.

3.1.7 Serial Interface

By way of hardware the serial interface is a RS-485 interface. The WIP1-3 relay can alternatively be provided with either Modbus Protocol or SEG-Pro Open Data Protocol. For protocol data please see the Profi-Pack file for Modbus or the SEG-Pro Open Data Protocol.

4. Working Principle

4.1 Analog circuits

The alternating currents induced by the main current transformers provide the WIP1's supply energy and form the measuring value. The measuring currents are galvanically isolated via the input transformers, decoupled from high-frequency interferences by analog RC-filters and then converted into current proportional voltages. The noise signals caused by inductive and capacitive coupling are suppressed by an analog R-C filter circuit. The analog voltage signals are fed to the A/D-converter of the microprocessor and transformed to digital signals through Sample- and Hold-circuits. The analog signals are sampled at 50 Hz (60 Hz) with a sampling frequency of 800 Hz (960 Hz), namely, a sampling rate of 1.25 ms (1.04 ms) for every measuring quantity. (16 samples per period).

4.2 Digital circuits

The essential part of the WIP1 is a powerful microcontroller. All of the operations - from the analogue/digital conversion to the relay trip decision - are carried out by the microcontroller digitally. The relay program is saved in an EPROM (Electrically-Programmable-Read-Only-Memory). With this program the CPU of the microcontroller processes the voltages applied at the analogue input circuits and calculates the basic current harmonics. For this calculation an efficient digital filter, based on the Fourier Transformation (DFFT - Discrete Fast Fourier Transformation) is applied to suppress high frequency harmonics and DC components caused by fault-induced transients or other system disturbances. The relay setting values for all parameters are saved in a parameter memory (EEPROM - Electrically Erasable Programmable Read-only Memory) and constantly compared with the actual current by the microprocessor. If a phase current exceeds the pickup value, an alarm is given and after the set trip delay has elapsed, the corresponding trip relay is activated. For continuous supervision of the program flow a "hardware watchdog" is installed. In case of failure, the watchdog timer resets the microprocessor and gives an alarm signal via the "self-supervision" output relay. Error of the program is indicated by the following display:

```
  _Internal_Fault__  
  -----
```

4.3 Battery buffer

The relay is provided with a battery fed clock IC so that the actual relay settings cannot be lost or parameters can be set, even if the power supply is interrupted. An empty or missing battery does not impair the proper working order of the relay.

4.3.1 Additional power part

The relay versions WIP1-2 and WIP1-3 include an additional power part. This power part serves for the self-supply of the relay. It does not provide the trip energy for the impulse output. The relays WIP1-2 and WIP1-3 will also function without this power part being connected. In that case they will only work with the functional scope of the WIP1-1.

4.3.2 Transformer Power Supply

Without additional auxiliary voltage supply the WIP 1 works, starting the following current values:

- single-phase starting approx. 0.35 A
- two-phase starting approx. 0.22 A
- three-phase starting approx. 0.17 A

4.3.3 Important note for the battery function

Battery Mode

By pressing the push-button <Display ON>, the relay is activated. WIP1-1 is supplied from the battery. This function is useful to allow setting of parameters without additional auxiliary voltage.

Operating range

- 1-phase up to approx. 0.07 A
- 2-phase up to approx. 0.06 A
- 3-phase up to approx. 0.05 A

Transformer Current Mode

The WIP1-1 is supplied by means of the current trans-formers.

Without additional auxiliary voltage supply, the WIP-1 works – starting the following current values:

- 1-phase, starting approx. 0.35 A
- 2-phase, starting approx. 0.22 A
- 3-phase, starting approx. 0.17 A

If the display shows a blinking minus sign, the WIP1-1 is just selecting one of the two operating modes. In this state, access to measuring values or parameters is not possible.

This display indication does not mean that the battery is defective or empty, but it is a further operating state. The same applies for the units WIP1-2 and WIP1-3, if the power supply unit is not applied.

4.4 Indicating and operating elements

4.4.1 Front plate

There are the following indicating and operating elements at the front of the relay:

- Two-line LC display with 16 characters per line
- Push buttons for adjustment and operation
- LED for trip indication

4.4.2 Display

All setting and measuring values as well as fault data are shown in the LC display.

4.4.3 LED

The trip status is indicated by the LED at the front. If the relay has tripped, the LED flashes and can be switched off by pressing any push button. Refer to chapter 5.7.4 and 5.9.

4.5 Function push buttons

The following four function push buttons are arranged at the front of the relay:

- <SELECT/RESET> "Select" = Selection of function displayed (short pressing of the push button) "Reset" = Reset of trip functions (long pressing of the push button, for 3s)
- <+> and <-> Selection of parameters
- <ENTER> Storing parameters
- <DISPLAY ON> Switching the relay on. If no key is pressed longer than 1 min. the relay switches off.

The push buttons <SELECT/RESET>, <+>, <-> and <DISPLAY ON> can be activated without removing the transparent cover by simply using a pin or screw driver.

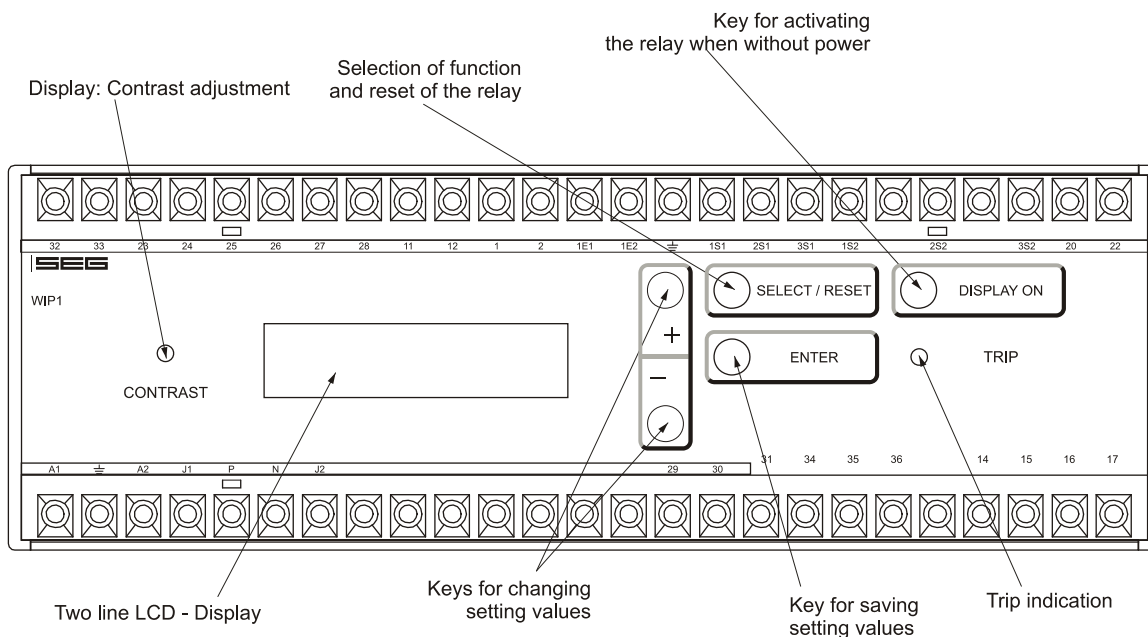

Figure 4.1: Front plate of WIP1

4.6 Opening the front cover

For adjustment of the unit the transparent cover has to be opened as illustrated. Do not use force!
The transparent cover has two inserts for labels.

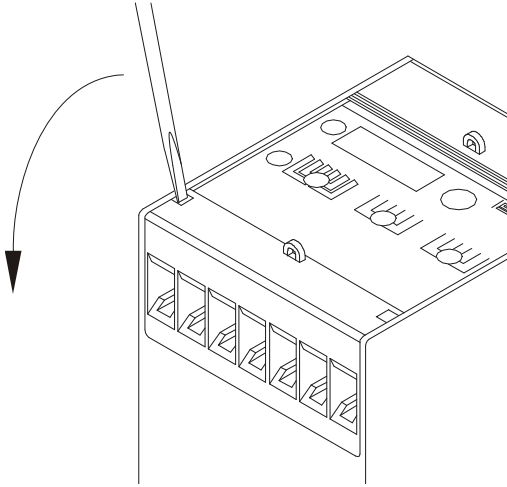

Figure 4.2: How to open the transparent cover

4.7 Requirements for the main C.T.s

The advantage of self-powered overcurrent relays is that they do not need any auxiliary power supply. This results from the fact that the overcurrent relay and the tripping unit receive their energy from the main C.T.s. The tripping principle of the WIP1 is that the transformer current is driven through the tripping coil in case tripping takes place. Care must be taken that the current transformer can transmit enough energy at the set overcurrent pickup value to activate the tripping coil, but does not generate too much energy at high short circuit currents which would damage the overcurrent relay.

Here some brief instructions on how tripping coil and current transformer are determined.

First of all it must be established how much force is required to cause the C.B. to trip. This force must be converted to electric energy. It can also be established by measurement. This value is very important. Many coils are defined by way of their rated data such as rated voltage, rated current, internal resistance and/or permissible on-period. These data do not permit any conclusions regarding the usability of a coil as the tripping capacity with rated data is usually much higher than is necessary for safe tripping.

4.7.1 Determining the maximum coil resistance

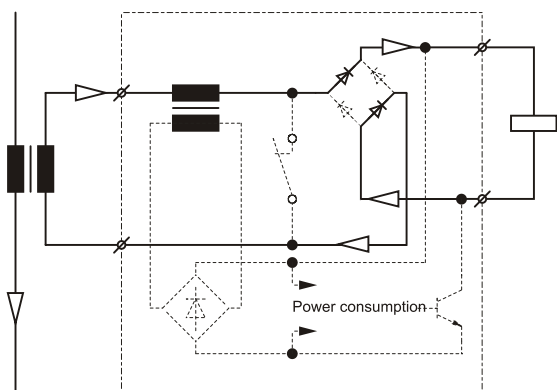

Figure 4.3: Tripping via current transformer $I < 12 \times I_n$

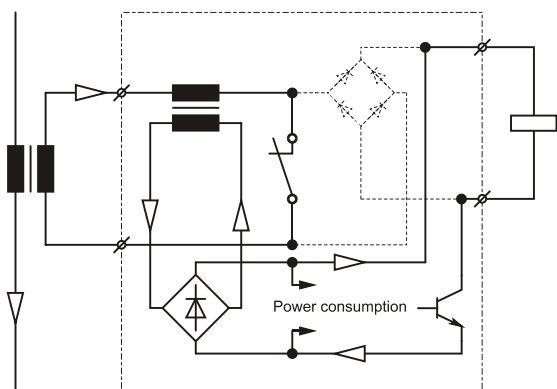

Figure 4.4: Tripping via self-supply as from $12 \times I_n$

The two diagrams show the two different tripping methods. In Figure 4.3 the tripping coil is supplied directly by the current transformer. In Figure 4.4 tripping is effected via an internal supply transformer. The result is that with tripping current $> 12 \times I_n$ the coil resistance must not be smaller than 17 Ohm. Once it has been established that the tripping current is smaller than $12 \times I_n$, the minimum possible coil resistance can be derived from Figure 4.5.

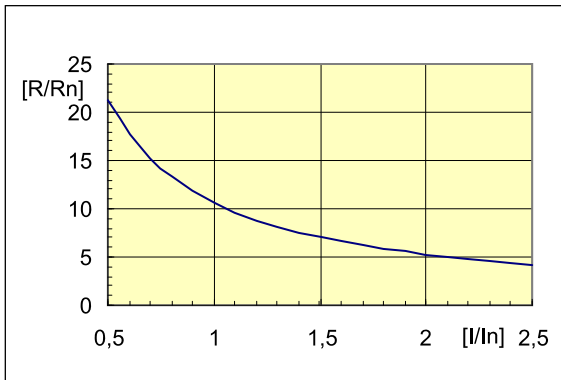

Figure 4.5: Minimum coil resistance

4.7.2 Characteristics of the current transformers

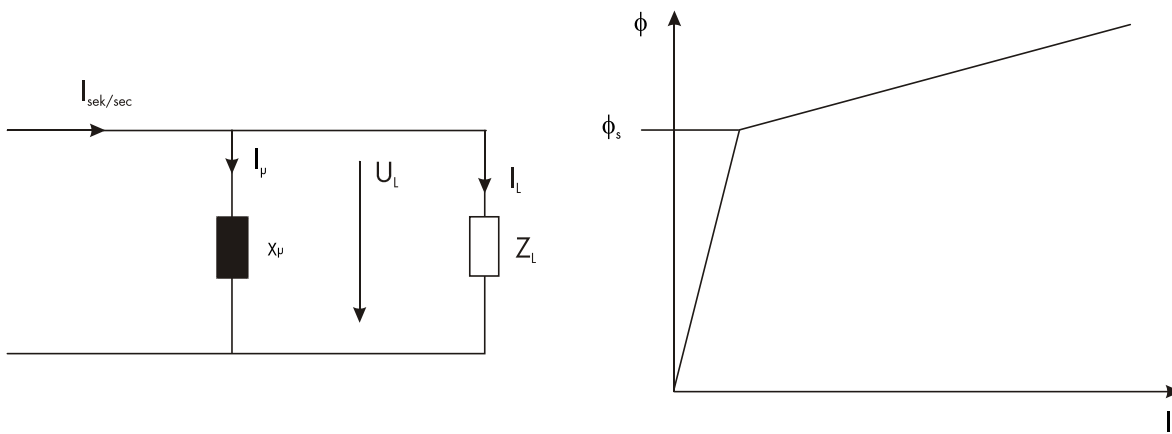

Figure 4.6: Circuit diagram of the secondary C.T. side and magnetizing curve

During normal operation the load of the current transformer is only the WIP impedance and the impedances of the connection cables. In case of tripping, the tripping coil also affects the transformer. Under any circumstances it must be prevented that this load has the effect that the transformer gets into saturation to such an extent that the current flowing through the coil becomes too low to ensure definite tripping.

The secondary transformer current I_{sec} is proportional to the primary transformer current and is a function of the transformation ratio. This current is divided into the magnetization current of the transformer and a current I_L which flows through the current paths of the overcurrent protection system.

The flux Φ is proportional to the voltage U_L and linked to the magnetization current I_μ via the magnetization curve. As from the value Φ_s the transformer moves into saturation. As a result the magnetization current grows overproportionally and the load current decreases at the same rate. So when the transformers are dimensioned it must be taken into account that with a known resistance Z_L the current I_L is still sufficient for tripping the coil. For this reason, the rated current of the tripping coil must be inserted for I_{Sp} in the calculation below. As the coil current I_{Sp} is a direct current, it must be converted into an effective AC value by means of eq. 1 or eq. 2. The result is, at the same time, the lowest switching point for possible tripping.

For tripping in case of a single-phase fault:

$$I_L = \frac{I_{Sp}}{0.9} \quad \text{eq. 1}$$

for tripping in case of a 3-phase fault:

$$I_L = \frac{I_{Sp}}{2} \quad \text{eq. 2}$$

The voltage U_L where the flux reaches the value Φ_s is called U_{max} in the following. Up to this point the trans-former is still working in its precision class and the cur-rent I_L is nearly as high as current I_{sec} .

The voltage U_{max} can be calculated as follows:

$$U_{max} = I_L \times Z_{Lmax} \quad \text{eq. 3}$$

The impedance Z_{Lmax} results from the WIP impedance, the cable impedances and the resistance of the tripping coil during tripping of the WIP1.

$$Z_{Lmax} = Z_{WIP} + Z_{Leit} + R_{Sp} \quad \text{eq. 4}$$

The impedance of WIP1 for the respective pickup value can be found in diagram 1 or diagram 2. The resistance of the tripping coil can be determined by measuring, or calculated from the rated data of the coil.

If a transformer is loaded with its rated impedance Z_N , the max. power of the C.T. can be determined as fol-lows:

First of all an explanation for the definition of the C.T. data:

Class: 10P20;

Class	10	P	20
Tolerance 10%			
Protection transformer (P)			
\ddot{u} (overcurrent factor)			

Capacity: S_N : 1.5 VA

S_N : Rated power with rated ohmic resistance and rated current

$$S_{max} = U_{max} \cdot \ddot{u} \cdot I_{Nsec}$$

with \ddot{u} : overcurrent factor of the current transformer eq. 5

The equation

$$S_{max} = Z_N \cdot (I_N \cdot \ddot{u})^2 \quad \text{eq. 6}$$

can be used to calculate the rated impedance of the current transformer as follows:

$$Z_N = \frac{S_{max}}{(\ddot{u} \cdot I_N)^2} \quad \text{eq. 7}$$

And finally, the rated power of the transformer can be calculated as follows:

$$S_N = Z_N \cdot I_N^2 \quad \text{eq. 8}$$

Caution:

With a setting value $\geq 12 \times I_N$ the resistance of the tripping coil must not be smaller than 17 Ω .

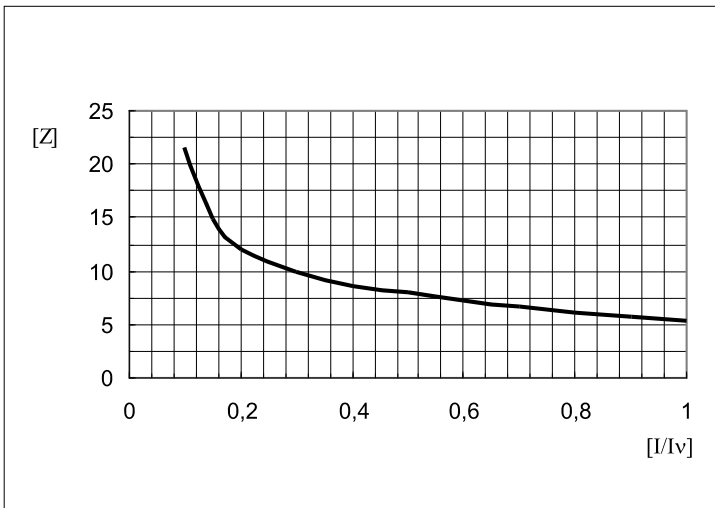

Figure 4.7: Diagram 1: WIP1 impedance curve for the range: 0.1A to 1A

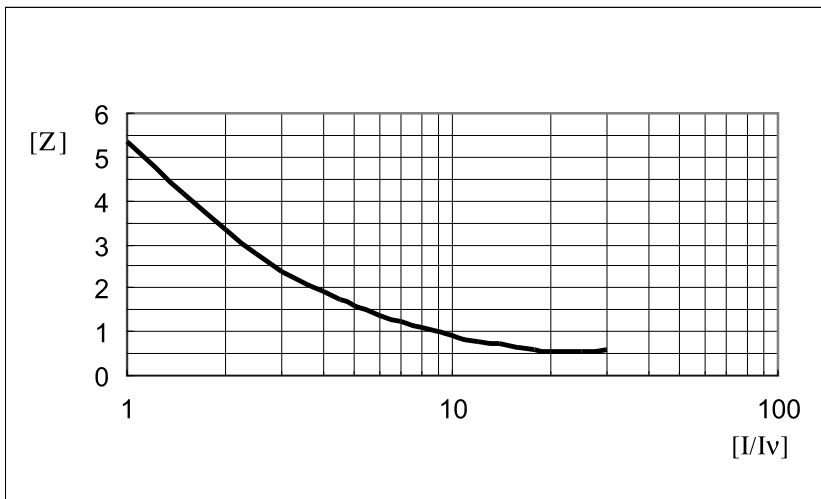

Figure 4.8: Diagram 2: WIP1 impedance curve for the range: 1 A to 30 A

4.7.3 Overloading of the WIP1

The maximum power consumption of the WIP1 must not exceed 1000 VA for the maximum tripping time.

The maximum power that a transformer can supply is calculated as follows:

$$S_{max} = S_n \cdot \ddot{u}^2 \quad \text{eq. 9}$$

This means the result for S_{max} must not be higher than 1000 VA.

4.7.4 Dimensioning example

For switching off a C.B. a tripping coil with a power of $P_N = 10 \text{ W}$ and a rated current $I_N = 0.45 \text{ A}$ is used.

As the rated current of the coil is a direct current, the setting value for the WIP1 for tripping with a single-phase fault must be calculated as per eq. 1. This results in a setting value of 0.5 A.

According to diagram 1 the impedance of the WIP1 at 0.45 A is approx. 8Ω .

The resistance of the coil can be calculated as follows if it cannot be determined by measuring:

$$R_{Sp} = \frac{P_N}{I_{Sp}^2} = \frac{10W}{(0.45A)^2} = 49.4\Omega$$

For this example the cable impedance is assumed to be 0.5Ω .

According to eq. 4 the maximum impedance is as follows:

$$Z_{max} = 57.9\Omega.$$

Now the maximum voltage U_{max} can be calculated with eq. 3.

$$U_{max} = 0.5 \cdot 57.9\Omega = 28.95V$$

If a current transformer class 10P10 is used the resulting overcurrent factor is $\ddot{u} = 10$. This permits calculation of the maximum power of transformer S_{max} in accordance with eq. 5.

$$S_{max} = 28.95V \cdot 10 \cdot 1A = 289.5VA$$

The rated impedance of the transformer is calculated in acc. with eq. 7.

$$Z_N = \frac{289.5VA}{(10 \cdot 1A)^2} = 2.9\Omega$$

And finally, eq. 8 can be used to calculate the rated power of the transformer.

$$S_N = 2.9\Omega \cdot (1A)^2 = 2.9VA$$

For this application a transformer with $S_N = 3 \text{ VA}$ of Class 10P10 is used.

Equation 9 must now be used to check whether the WIP1 is possibly overloaded.

$$S_{max} = 3VA \cdot 10^2 = 300VA < 1000 \text{ VA}.$$

This means that this current transformer can be used.

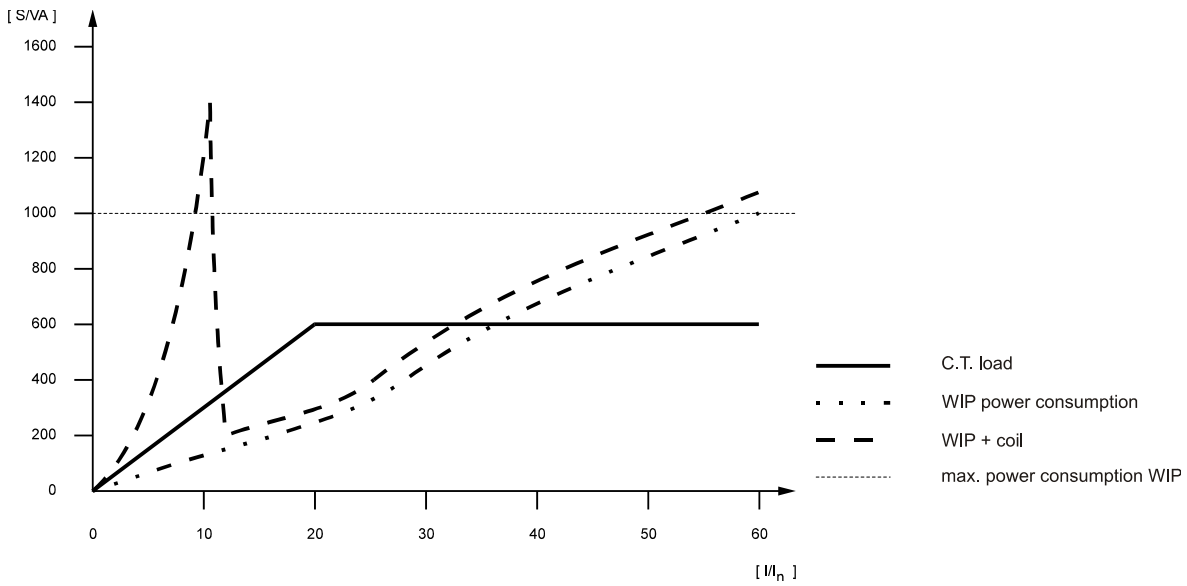

Figure 4.9: WIP1 - power consumption

The graph shows the limit value of the load to which the WIP1 may be subjected in case of a short circuit. In the event that the transformer power nevertheless exceeds the limit value, it is possible to connect resistors in series into the secondary circuit.

5. Operations and settings

By the following figure operation of the WIP1 is illustrated. The different menus can be selected by pressing push button <+> or <-> and then called up by the <SELECT/RESET> push button. If the relay is activated by transformer current the main menu is displayed. The different menus can be selected by pressing <SELECT/RESET>.

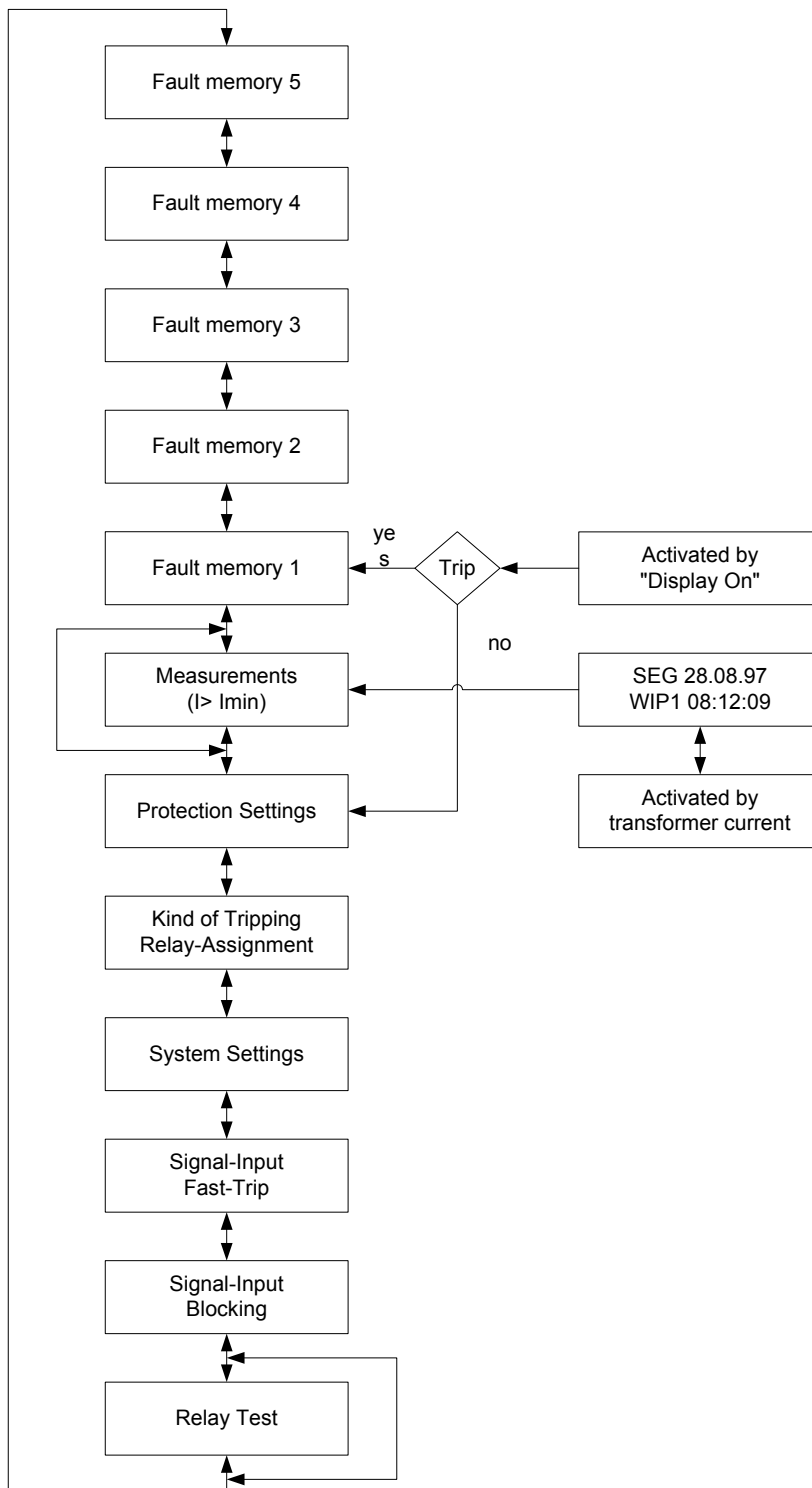

Figure 5.1: Main menu overview

5.1 Function of push buttons

The push buttons are used for calling parameters, selecting the measuring quantities to be displayed and for changing and saving of parameters.

The different menus can be selected by pressing push button <+> or <-> and then called up by the <SELECT/RESET> push button. If this push button is pressed for longer than 3 s, the display is reset.

By push button <ENTER>, the set and displayed values are saved in the internal parameter memory. Incidental or unauthorized changing of parameters is prevented by an obligatory password (see chapter 5.1.4).

Push button <DISPLAY ON> is to activate fault indication or for setting modes. Should no push button be actuated for 60 s, the relay switches off automatically.

By pressing push buttons <SELECT/RESET>, <+> and <-> simultaneously and then activation of the relay by the <DISPLAY ON> push button, the default settings of the relay are recall from the parameter memory.

```

DEFAULT_SETTINGS
___AKTIVATED___

```

5.1.1 Measuring value and fault indication

Display when the relay is de-energized:

The relay is only activated after the <DISPLAY ON> push button has been pressed. When the battery voltage is too low (<3 V), the following is displayed:

```

BATTERY_Voltage_
___to_low_____

```

If the battery voltage is within the permissible range, the following is displayed:

```

>>>PROTECTION<<<
>>>>SETTINGS<<<<

```

In this mode measuring values cannot be read because the measuring mode is only activated if C.T. current is available.

If supply is present via C.T.s the following is indicated on display:

```

ISEG___15.04.97
WIP1-1_12:16:09

```

This display is referred to as 'Main Menu' and can be entered from any menu point by pressing the <SELECT/RESET> push button for about 3 s. This is the push button all fault stores and parameter blocks can be selected with.

Note!

If supplied via C.T.s a faulty battery or battery voltage to low will be indicated too.

Display if a minimum current is exceeded:

When C.T. current is available, the relay is activated at the smallest possible phase current. Displayed are automatically date and time.

In this mode measuring values can be called at any time.

Display after tripping:

If the relay has tripped, the internal power supply is disconnected and only the LED flashes. By pressing <DISPLAY ON>, the relay is re-connected. The tripping values are displayed after pressing the <SELECT/RESET> push button.

```
>>>>>FAULT<<<<<
>>>>Memory_1<<<<<
```

5.1.2 Display

The menu of the data displayed can be subdivided into five groups:

- Measuring values
- Protection parameters
- Kind of tripping/relay assignment
- System parameters
- Signal input parameters
- Fault memory
- Relay test

The fault memory consists of five individual stores of identical configuration.

For changing from the main menu to the first of the submenus, the <SELECT/RESET> push button is shortly to be pressed. From here the single groups can be selected via push buttons <+> and <->. To proceed to any of the individual menu points, push button <SELECT/RESET> is to be pressed.

5.1.3 Setting procedure

After a parameter value has been selected, it can be adjusted to the required value by push buttons <+> and <->.

5.1.4 Parameter setting by using the password

When the <ENTER> push button has been pressed, the following information is displayed:

```
>>>>Parameter<<<<
store_value_?_<<<<
```

If the changed value is to be saved, the <ENTER> push button has to be pressed again shortly. Now the display is shows:

```
>>>>Parameter<<<<
Password:_xxxx_<<<<
```

After the password has been entered and acceptance is confirmed by message:

```
>>>>Parameter<<<
store_value!___
```

the <ENTER> push button is to be pressed for about 3 seconds. The initially selected parameter with the changed value is displayed and activated.

For the password any combination of the following four push buttons can be used:

Push button	<SELECT/RESET>	=	S
Push button	<->	=	-
Push button	<+>	=	+
Push button	<ENTER>	=	E

For instance, for password „-E+S“ the order of push buttons is as follows:

<-> <ENTER> <+> <SELECT/RESET>

The initial password reads: ++++

The place for entering the information is marked by the letter „x“ on the display. If a wrong password is entered, this is indicated by the information:

```
>>>>Parameter<<<
Wrong_Password__
```

By pressing the <ENTER> push button, the password can be entered again.

After the password has been accepted, parameters can be set for 5 minutes without re-entering the password. During this time the procedure for saving a new value is as follows:

Message "Store value ?" to be acknowledged by pressing the <ENTER> push button and then after display of message "Store value !" prolonged pressing of the <ENTER> push button. Provided the next setting procedure has started within the 5 minutes limit, the setting time is prolonged for further 5 minutes, otherwise the password has to be entered again.

5.2 Display of measuring values

```
>>MEASUREMENTS<<
>>>>DISPLAY<<<<<
```

Measuring values can be displayed during operation only. The C.T. current should sufficiently be rated to ensure power supply for the relay.

```
L1=0.85_L2=0.87_
L3=0.95__E:0.00_
```

The measuring values (secondary C.T. currents) are direct shown in ampere. These values are not displayed if the event is of energizing nature only.

A peak value is measured as well:

```
L1^0.99_L2^0.98_
L3^0.98__E^0.00_
```

This value is saved in the fault memory when below the pick-up value or in case of tripping. For an inverse time characteristic the pick-up time during the pick-up phase is stored.

```
>>Pickup_Time<<<
t>=0.00%_tE>=0.0%
```

5.3 Displaying the pickup phase

If a pickup value is exceeded, the display will show the pickup time.
If the pickup value drops below the threshold before tripping takes place, the measuring values are displayed.

5.4 Display of tripping values

```
>>>>FAULT<<<<<<
>>>>MEMORY_1<<<<
```

The fault memory provided in the WIP1-1 can save up to five trip events. The individual registers are selected by push buttons <+> and <->. Configuration of all registers is identical.

```
>>>>>TRIP<<<<<<
I>__L1_xx_xx_x_
```

In the display an overcurrent trip with current increase in phase L1 is shown. Currents in the other two phases were below the trip value.

The following faults can be displayed:

```
I> Overcurrent
I>> Short circuit
IE> Earth fault current
IE>> Earth fault
FAST Fast trip
EXT External trip
```

```
L1=4.05_L2=0.87_
L3=0.90__E=0.00_
```

Here the current values at the trip instant are displayed in ampere.

These values are not displayed if the event is of energizing nature only.

A peak value measured at the C.T. during the pick-up phase is displayed.

```
L1^5.46_L2^2.81_
L3^2.82__E^0.00_
```

From the energizing time displayed can be concluded whether trippings have occurred.

```
>>Pickup_Time<<<
t>=100%_tE>=2.0%

Date___15.04.97
Time___15:26:45
```

The exact time the trip occurred is also recorded. After pressing the <SELECT/RESET> push button, message „Fault memory 1“ is displayed again.

Example: When selecting an inverse time characteristic a reset time of 300 s is set and the following information can be gathered in failure cases:

- Number of energizing events
- Max. current during each of the energizing events
- Duration of the individual energizing events
- Time interval between two energizing events
- Interval between the energizing phases
- Tripping time
- Tripping value at the instant of shut-down

5.5 Protection parameters

5.5.1 Pickup value for phase overcurrent element

The pickup value for the phase overcurrent element I> is displayed as secondary C.T. current in ampere.

```
>>>Overcurrent<<
I>___=0.95_A___
```

If this pickup value is set to "EXIT", the overcurrent trip is blocked.

5.5.2 Time current characteristics for phase overcurrent element

```
>Characteristic<
Normal_Inverse__
```

By setting this parameter one of the following nine messages appears on the display:

Definite_time protection:

Definite_time

Inverse_time protection:

Normal_Inverse

Very_Inverse

Extremely Inverse

RI-Inverse

Long Time Inverse

X²_Time

X^{2.5}_Time

X³_Time

X^{3.5}_Time

X⁴_Time

The text displayed can be changed by <+> <-> push buttons. By the <ENTER> push button the required characteristic is selected.

5.5.3 Trip delay or time multiplier for phase overcurrent element

After the characteristic is changed, usually the time de-lay or time multiplier should be changed accordingly.

```
>>>Time_Factor<<
tI>_=_0.50_____
```

When the "Inverse time" characteristic has been chosen, the time factor tI> is displayed; this also can gradually be changed by push buttons <+> and <->.

```
>>Tripping_Time<
tI>_=_0.35_s_____
```

When the „Definite time“ characteristic has been chosen, the respective time displayed is to be understood in seconds which can gradually be changed by push buttons <+> and <->.

5.5.4 Reset mode for inverse time tripping characteristics for phase over-current element

```
>>>Reset-Modus<<
t_=_300s_____
```

To ensure tripping, even with recurring fault pulses (packing faults) shorter than the set trip delay, the reset mode for inverse time tripping characteristics can be switched over. For adjustment $t = 60$ s or 300 s, the tripping time is maintained accordingly and only reset after 60 s or 300 s faultless condition. This function is off if t is set to 0. With breaking fault current, the trip delay is reset immediately and started again at recurring fault current.

5.5.5 Minimal time

This function is active with all inverse time tripping characteristics. It ensures that the trip delay is not faster than the set value.

```
>>Minimal_time<<
>>tImin=_0.1_s<
```

Note:

The minimum time cannot be set lower than the shortest trip delay of a tripping characteristic.

The latter depends on the multiplier of a tripping characteristic.

Example: selected characteristic x^4 -time

Factor: 0.8

The lowest adjustable minimum time then amounts to 0.16 s. This value is automatically increased if the multiplier of the characteristic is increased.

5.5.6 Current setting for high set element

The pickup value for the high set element appearing on the display is related to the secondary C.T. current given in ampere.

```
>>Schort_Circuit<
I>>_2.20_A_____
```

When this pickup value is set to infinity (on the display appears „EXIT“), the high set element of the relay is blocked.

5.5.7 Trip delay for high set element

Irrespectively on the trip characteristic chosen for $I>$, the high set element $I>>$ has always a definite time tripping characteristic. The indication value is displayed as seconds.

```
>>Tripping_Time<
tI>>=_0.35_s____
```

5.5.8 Pickup value for earth fault current element

The pickup value for the earth fault current element IE> is given in ampere as secondary C.T. current.

```
>>>Earth_Fault<<
IE>_0.05_A_____
```

If this pickup value is set to EXIT, the earth fault current element is blocked.

At WIP1-1 the earth fault current element is only activated if the current flowing in at least one of the phases is higher than the lowest adjustable threshold of the phase overcurrent element (0,5 A). At WIP1-2 the external power supply must be in operation.

5.5.9 Tripping characteristic for earth fault current element

```
>Characteristic<
Normal_Inverse__
```

When adjusting the tripping characteristic one of the four following possibilities are displayed:

Definite time characteristics

Definite time earth fault current protection

Inverse time earth fault current protection

Normal Inverse

Very Inverse

Extremely Inverse

RI-Inverse

Long time Inverse

The text displayed can be changed by keys <+> and <->. When pressing <ENTER> the respective characteristic is chosen.

5.5.10 Trip delay or time multiplier for earth fault overcurrent element

(refer to 5.5.3)

5.5.11 Reset mode for normal inverse time tripping characteristics for earth fault element

(refer to 5.5.4)

5.5.12 Minimum tripping time (earth fault element)

(refer to 5.5.5)

5.5.13 Current setting for earth fault high set element

(refer to 5.5.6)

5.5.14 Trip delay for earth fault high set element

(refer to 5.5.7)

5.6 System parameters

5.6.1 Selection of the language

```
>>>>SYSTEM<<<<
>>>>SETTINGS<<<<
```

Language for the messages displayed is either German or English.

```
>>>PARAMETER<<<<
Language_English
```

The language can be chosen by push buttons <+> and <->.

5.6.2 Password programming

This is the menu for changing an existing password.

```
>>>Parameter<<<<
_New_Password_?_
```

This inquiry is acknowledged by push button <ENTER>. By pressing push button <SELECT/RESET> this procedure is stopped and the next parameter is indicated.

```
Name_old_____
Password!_xxxx_
```

To activate a new password, the existing one has to be entered first.

```
_1st_input_____
_Password:_xxxx_
```

The new password can be entered by push buttons <SELECT/RESET>, <ENTER>, <+> and <->. The place for entering the information is marked by the letter „x“ on the display.

```
_2nd_Feed_____
_Password:_xxxx_
```

The password entered here must correspond with the one entered before. If this is not the case, the following message is displayed:

```
>>>Parameter<<<<
Incorrect_Input_
```

By shortly pressing the <SELECT/RESET> key, the new password can be entered again. When the right password is entered, this is acknowledged by the following message:

```
New_Password____
is_active!_____
```

By pressing the <SELECT/RESET> push button, the next parameter is indicated.

5.6.3 Date setting

The cursor underneath the date displayed signals that the date can be changed. For setting the correct day push buttons <+> and <-> are to be used. At first input of the correct password is required. The set value then to be acknowledged by the <ENTER> push button or proceeding to the next parameter by the <SELECT/RESET> push button. The same procedure applies for setting month and year.

```
>>>>Parameter<<<<
Date_16.04.1997_
```

5.6.4 Time setting

The same procedure applies for setting the time.

```
>>>>Parameter<<<<
Time____11:56:08
```

5.6.5 Rated frequency setting

The adapted FFT algorithm requires the rated frequency of the object to be protected as a parameter for exact digital sampling and filtering of the input currents. Displayed is either "f_N = 50 Hz" or „f_N = 60 Hz“.

```
Rated_Frequency_
fN_50_Hz_____
```

The rated frequency required can be adjusted by <+> or <-> and then saved by <ENTER>.

5.6.6 Adjustment of the slave address (WIP1-3)

```
>>>>Slave_Address<<
No._=_1_____
```

By pressing keys <+> or <-> the slave address can be set within a range from 1 - 32.

5.6.7 Baud Rate setting (WI1-3)

```
>>>>Baud_Rate<<<
___9600_Baud___
```

The baud rate can be set by keys <+> and <-> and then be saved by pressing <ENTER>.

5.6.8 Setting of parity

```
>>Parity_Check<<
_____even_____
```

The following three parity settings are possible:

```
even parity
odd parity
no parity
```

The setting can be changed by push buttons <+> and <-> and saved by pressing <ENTER>.

5.6.9 Indication of the software version

In this point of the menu, the number of the relay soft-ware version can be called up. When receiving the relay description it always should be checked whether the description really applies for the actual relay soft-ware version (a respective note can be found in the index).

```
Software_Version
V02-1.00_____
```

5.7 Tripping method/Relay matrix

5.7.1 Reset

Here we have to distinguish whether the LED and the bistable relay 1 are to be reset automatically or manually. Refer to Chapter 5.9

```
>>>>RESET<<<<
Manuell_____
Automatisch_____
```

5.7.2 Tripping method

This is to determine whether the C.B. is activated direct via the electric pulse output or if to be switched via an interposing C.T. circuit (see figure 3.2 and 3.3).

```
Kind_of_Tripping
Electro_Pulse___
```

Note:

If parameter is set on electric-pulse the output relay will also operate in case of tripping.
If parameter is set on relay the electric impulse output doesn't connect with a trip coil.

5.7.3 Earth fault overcurrent

The trip relay can be assigned to the different trip elements and it can be defined whether the earth fault overcurrent function IE> should result in tripping.

```
Earth-Fault_IE>_
Alarm_____
```

In this case alarm means that tripping of the latched re-lay at the electric impulse output and activation of the LED are prevented. Exceeding of the pickup value incl. expiring of the tripping time is here regarded as activation only.

5.7.4 Flashing of the Trip-LED

The power that is required for LED flashing is exclusively supplied by the battery. Therefore, it is recommended to shortly reset LED flashing. If this is not possible, the trip indication function of the LED "TRIP" can be de-activated.

```
>>TRIP-LED<<<
Flashing_____
```

The LED reset can be done by activating the reset function (please refer to chapter 5.9)

5.7.5 Relay matrix (only relay 2)

This is to determine whether the trip relay should energize or not a function specified.

Attention:

A relay assignment is only available for the versions WIP1-2 and WIP1-3. WIP1-1 does not provide an assignment facility.

The following setting variants are possible:

```
_D__Alarm:_Nein
_D__Trip: __Ja__
_D>_Alarm:_Nein
_D>_Trip: __Ja__
IE>_Alarm:_Nein
IE>_Trip: __JA__
IE>>_Alarm:_Nein
IE>>_Trip: __Ja__
```

5.8 Signal inputs

5.8.1 Fast trip

By this operating input a fast trip can be initiated if a specific minimum current flows via the measuring C.T.s. Adjustable are two kinds of fast tripping:

```
>>>FAST_TRIP<<<<
Immediately_____
```

Here a trip occurs when the C.T. current in at least one phase is sufficient to supply the relay.

```
>>>Fast_Trip<<<<
After_Pickup_____
```

Here a trip occurs when the current flowing is higher than the set threshold.

5.8.2 Blocking the protection functions

The blocking function of the WIP1 can be set acc. to requirement. By applying the aux. voltage to terminals 14 and 17 the functions chosen by the user are blocked.

```
Block._Function_
ID_No_____
```

For the "Yes" or "No" entry, push buttons <+> or <-> are to be used. This applies for the overcurrent element, short circuit element and if available earth fault overcurrent and high set element.

5.9 Reset

There are four possibilities for resetting the WIP1 as well as the relay 1/latched.

The parameter setting mode under menu item Tripping type/ Relay configuration offers the parameter Reset. Here once can choose whether the LED and the bistable relay 1 can be reset automatically or manually.

Manual Reset

If the display is on by pressing the <SELECT/RESET> push button for some time (about 3 s). Reset are: the display, LED and the bistable relay 1.

Automatic reset

In case of automatic resetting the bistable relay 1 and the LED are reset by applying the transducer current.

WIP1-1:

The LED extinguishes and the bistable relay 1 is reset if sufficient current is available to put the WIP1-1 into function.

1 – phase from approx. 0.35A

2 – phase from approx. 0.22A

3 – phase from approx. 0.17A

WIP1-2/WIP1-3:

The LED extinguishes and the bistable relay 1 is reset the auxiliary power supply is switched on (dual-powered) and the transducer current is $>5\% \times I_n$ with phase current and $>2\% \times I_n$ with earth current. If no auxiliary voltage is connected, the function is analogue to that described for the WIP1-1.

Automatic resetting can only take place approx. 3s (± 1 s) after a tripping action. This does take possible switch failure times into account.

In addition, with automatic resetting it is not the fault memory that is displayed upon activation of the relay by the transducer current, but the date and time.

External reset

Applying voltage resets the signal relay and extinguishes the LED. The Display reads:

```
>External_Reset<
>>>activated<<<<
```

The display is maintained as long as the voltage signal is applied.

Note:

The voltage signal puts the battery under load.

For this reason it should be kept as short as possible.

Software Reset (optionally)

Resetting of a displayed message, of the LED and also of the output relay can be realized via RS485 interface. The effect of the Software Reset and the Manual Reset is the same.

5.10 Clearing the fault memory

Pressing push buttons <-> and <SELECT/RESET> (approx. 3 s) at the same time results in clearing the fault memory.

6. Relay testing and commissioning

The test instructions following below help to verify the protection relay performance before or during commissioning of the protection system. To avoid a relay damage and to ensure a correct relay operation, be sure that:

- the rated current of the relay corresponds to the plant data on site.
- the current transformer circuits are connected to the relay correctly.
- all signal circuits and output relay circuits are connected correctly.

6.1 Checking the set values

Pressing the <DISPLAY ON> push button activates the display. By repeatedly pressing the push button <SELECT/RESET>, all relay set values may be checked. Set value modification can be done with the push button <+><-> and <ENTER>.

For a correct relay operation, be sure that the frequency set value (f=50/60) has been selected according to your system frequency (50 or 60 Hz).

6.2 Secondary injection test

6.2.1 Test equipment

- Ammeter with class 1 or better
- Single-phase voltage supply unit (adjustable from 0 to 260 V AC)
- Inductance (S = 2.5 KVA, L = 65 mH, I = 10 A)
- Timer to measure the operating time (Accuracy class $\leq \pm 10$ ms)
- Switching device
- Test leads and tools

6.2.2 Example of test circuit

For testing WIP1 only current input signals are required. Figure 6.1 shows a simple example of a single phase test circuit with adjustable current energizing the WIP1 relay under test.

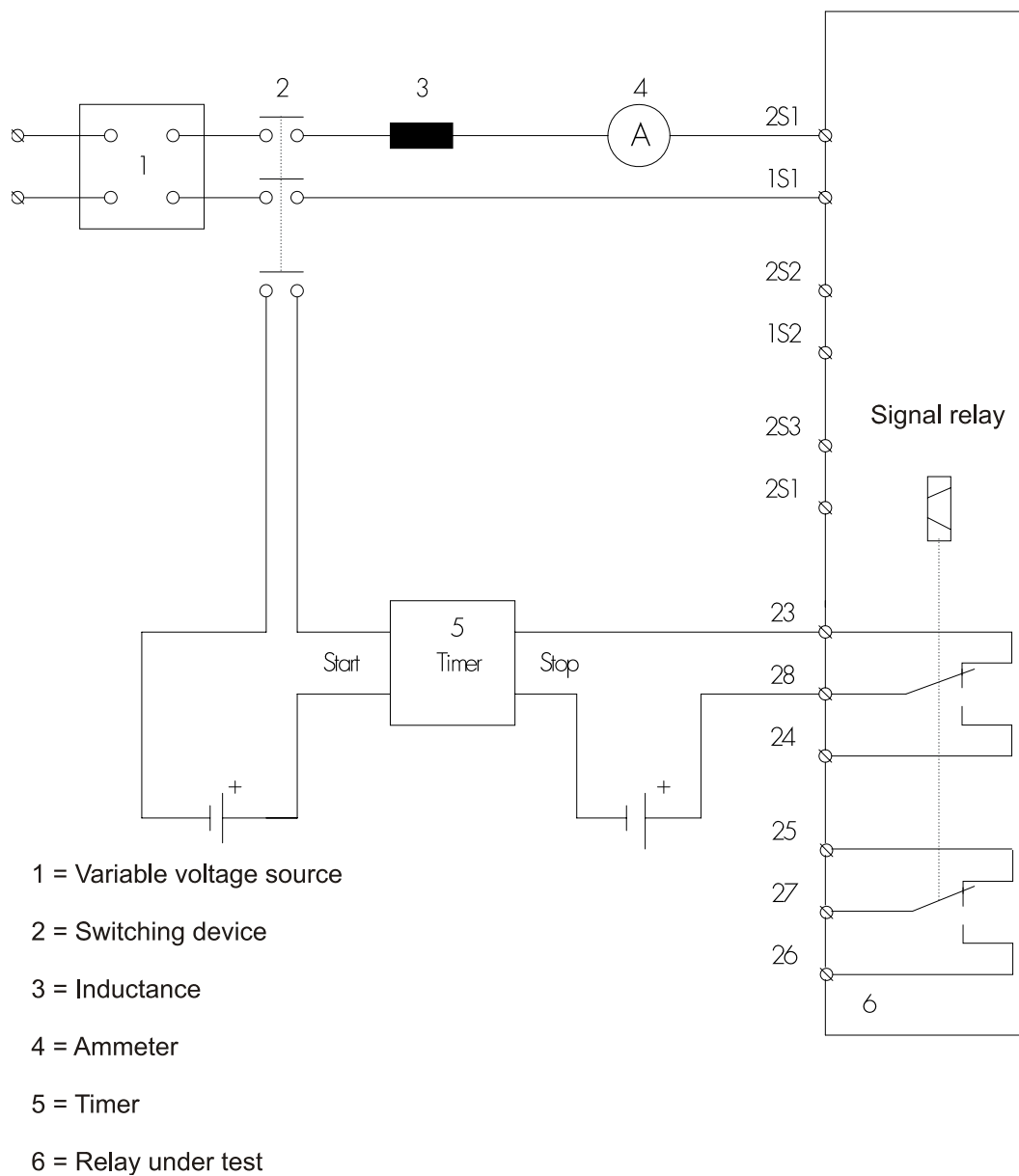

Figure 6.1: Test circuit

6.2.3 Checking the tripping circuits

Parameter <SIGNAL INPUT BLOCKING> is followed by

```
>>>>RELAY-<<<<<
>>>>TEST<<<<<<<<
```

This mode can only be entered in battery operation, i.e. when there is no current flowing. By pressing push button <SELECT/RESET> the test mode is entered and the password queried.

```
>>>Relay_Test<<<
_Password:_xxxx_
```

Pre-condition for entering the relay test mode is that the test current has been applied within 30 s. If the time has elapsed, the program returns to the standard mode and the display shows:

```
>>>PROTECTION<<<
>>>>SETTINGS<<<<<
```

After entering the correct password, the trip mode starts upon the following inputs.

```
>>TEST_CURRENT<<
>>SET_TO_>1Amp<<<
```

When 1 A is reached, test of the relay begins. The protection function is blocked through the test procedure because exceeding of the set threshold would result in tripping. The display shows:

```
>>>Relay_Test<<<
>>>is_running<<<<
```

In the following the test procedure is described in de-tail.

Test: Electro pulse output
 Test: Alarm relay
 Test: Flag indicators

These outputs are controlled for 150 ms and since they are controlled by a common processor signal, they can only be tested together. The alarm relay remains energized.

Break of 1s

Self-test relay energizes for 1s

Break of 1s

TRIP-LED is blinking.

The display shows:

```
>>>>>PRESS<<<<<
>SELECT-BUTTON<<
```

After this push button has been pressed, the alarm relay and self-test relay are de-energized and the LED should extinguish.

```
>>Test_current<<
>>>switch-off<<<
```

The WIP1 indicates disconnection of the test current by the following message:

```
>>>>>RELAY-<<<<<
>>>>>TEST<<<<<<
```

Should the test current be so low that the coil fails to trip, the test will be stopped.

```
>>Test_stopped<<
>arrest_current<
```

6.2.4 Checking the input circuits and measured values

Inject a current, which is less than the relay pickup current set values, in phase 1 (terminals 1S1-1S2), and check the measured current on the display by pressing the push button <SELECT/RESET>. The current can be also injected into the other current input circuits (Phase 2: terminals 2S1-2S2, Phase 3: terminals 3S1-3S2). Compare the displayed current value with the reading of the ammeter. The deviation must not exceed 5% I_N . By using an RMS-metering instrument, a greater deviation may be observed if the test current contains harmonics. Because the WIP1 relay measures only the fundamental component of the input signals, the harmonics will be rejected by the internal DFFT-digital filter. Whereas the RMS-metering instrument measures the RMS-value of the input signals.

6.2.5 Checking the overcurrent element

To check the relay operating time, a timer must be connected to the trip output relay contact. The timer should be started simultaneously with the current injection in the current input circuit and stopped by the trip relay contact. Set the current to a value corresponding to twice the operating value and inject the current instantaneously. The operating time measured by the timer should have a deviation of less than 3% of the set value or ± 10 ms (DEFT). Accuracy for inverse time characteristics refer to IEC 255-3.

Repeat the test on the other phases or with the inverse time characteristics in the similar manner. In case of inverse time characteristics the injected current should be selected according to the characteristic curve, e.g. two times I_S . The tripping time may be read from the characteristic curve diagram or calculated with the equations given under "technical data".

Please observe that during the secondary injection test the test current must be very stable, not deviating more than 1%. Otherwise the test results may be wrong.

6.2.6 Checking the high set element of the relay

The high set element of the WIP1 is checked in the same manner. It is important, however, that the selected test current is not too high because of trip delay at inverse time characteristics may become shorter than the high set setting. The reason is that both tripping signals operate the same tripping relay or the same electric impulse output.

Note !

Where test currents $> 2.5 \times I_N$ are used, the thermal withstand capability of the current paths has to be considered (see technical data, chapter 7).

6.2.7 Checking the external blocking

The external blocking input inhibits e. g. the function of the high set element of the phase current.

For this purpose the parameter "Blocking Function" in the menu "Signal input blocking" for the high set element must be set to "Yes". Then the terminals 14 and 17 are supplied with auxiliary voltage (e.g. 110 V DC).

The time delay $t_{I>}$ should be set to EXIT for this test. Inject a test current which could cause a high set ($I>$) tripping. Observe that there is no trip and alarm for the high set element.

Remove the auxiliary supply voltage from the blocking input. Inject a test current to trip the relay (message „TRIP“ on the display). Interrupt the test current.

6.2.8 Checking the input "Fast trip"

The "Fast trip" function allows the unit to be tripped within the shortest possible time. A prerequisite for correct tripping is the correct setting of the parameters. In the menu "Signal input - fast trip" the setting should be "instantaneously". If a current is now injected which is greater than the lowest adjustable overcurrent threshold and an auxiliary voltage (110 V DC) is supplied to the terminals 32 and 33, tripping takes place instantaneously ($t_{I>}=50\text{ ms} \pm 10\text{ ms}$).

6.2.9 Remote trip

Checking the input "Remote trip" does not require any test current. The terminals 20 and 22 are provided with supply voltage (230 V AC $\pm 20\%$). This leads to tripping within 200 ms.

Caution!

These terminals may only be supplied with voltage for a maximum of 2 min.

6.2.10 Test of input „External Reset“

For testing this function, voltage is to be applied to terminals 14 and 15. The relay is activated now by it-self and in the display appears „External reset activated“.

6.2.11 Checking the battery

The battery test is carried out by pressing the key <DISPLAY ON>. If the display indicates "Protection parameter", the battery is ok.

Note:

Relays which have been out of order for more than one month might show "Battery voltage too low" on the display when the key <DISPLAY ON> is first pressed. The reasons for this are that, on the one hand, the capacitors are completely discharged and, on the other hand, the long storage time of the battery.

But before replacing the battery the power supply has switched off and the <DISPLAY ON> key is pressed again. If "Battery voltage too low" is indicated again, the battery does need replacing.

6.2.12 Loss of information due to non-existent or empty battery

If the battery is missing or empty the stored information of the IC can be lost when the relay is switched-off. The following information is stored:

1. Date and time
2. Elapsed energizing time for detecting intermediate faults. (60s/300s).
3. Error memory
4. Status word for detecting hardware faults

When the relay is switched on, the following information can be displayed by means of the CT current or by pressing the key „Display On“.

Display of time and date begins with induction of the CT current.

```
ISEG___00.00.00
WIP1___00:00:00
```

The figure indicating the year might perhaps show un-defined values.

In cases the error memory fails and the energizing time has perhaps elapsed, the following text is displayed:

```
>>Loss_of_Data<<
>>Press_Reset<<<
```

The information will be indicated until the key <SELECT/RESET> has been pressed for 3s; thereafter the following is displayed:

```
>>Faultmemory<<<
>>>>cleared<<<<<
```

If during this process the CT current exceeds a value of 0.5A in one phase, the self-supervising relay energizes for 1s.

Data is read or processed permanently via the I2 C bus of the processor. Should this communication be disrupted, the following is displayed:

```
>Internal_Fault<
>>Press_Reset<<<
```

If during this process the CT current exceeds a value of 0.5A in one phase, the self-supervising relay energizes for 1s.

If these fault signals can be reset, then it is only an one-off incident and the WIP1 has not to be switched off.

6.3 Primary injection test

Generally, a primary injection test could be carried out in the similar manner as the secondary injection test described above. Since the cost and potential hazards are very high for such a test, primary injection tests are usually limited to very important protective relays in the power system.

Because of its powerful combined indicating and measuring functions, the WIP1 relay may be tested in the manner of a primary injection test without extra expenditure and time consumption. In actual service, for example, the measured current values on the WIP1 relay display may be compared phase by phase with the current indications of the ammeter of the switchboard to verify that the relay works and measures correctly.

6.4 Maintenance

Maintenance testing is generally done on site at regular intervals. These intervals vary among users depending on many factors: e.g. the type of protective relays employed; the importance of the primary equipment being protected; the user's past experience with the re-lay, etc.

For electromechanical or static relays, maintenance testing will be performed at least once a year according to the experiences. For digital relays like WIP1, this interval can be substantially longer. This is because:

- the WIP1 relays are equipped with very wide self-supervision functions, so that many faults in the relay can be detected and signaled during service. Important: The self-supervision output relay must be connected to a central alarm panel!
- the combined measuring functions of WIP1 relays enable supervision the relay functions during service.

A testing interval of two years for maintenance will, therefore, be recommended.

During a maintenance test, the relay functions including the operating values and relay tripping characteristics as well as the operating times should be tested.

7. Technical data

Measuring input

Rated data:	Rated current $I_n = 1 \text{ A}$, 50/60 Hz
Thermal withstand capability in current circuit:	dynamic current withstand (half-wave)
	for 1 s 135 x I_n
	for 10 s 54 x I_n
	continuously 17 x I_n
	2.5 x I_n

Input Remote tripping

Rated voltage:	230 V AC, max. 2 min power consumption 30 VA/230 V
Trip delay:	<200 ms at $U = 230 \text{ V} \pm 20\%$
Trip:	Periodically for the input voltage range from $U = 0.8$ to $1.2 \times U_N$ if there is no current flowing.

Signal inputs

Rated voltage:	110 V AC/DC
Pickup threshold:	$U_{on} \geq 80 \text{ V AC/DC}$ $U_{off} \leq 45 \text{ V AC/DC}$
Power consumption:	1 mA DC or 6 mA AC
Max. voltage:	270 V AC or 360 V DC continuously

Electro pulse output circuit

Tripping:	Recurring cycle with 8 pulses of 150 ms each. (For currents <12A AC $\pm 10\%$ the trip energy is supplied directly by the C.T.).
Transmitted tripping energy acc. to 150 ms tripping pulse:	1.5 Ws that corresponds to 10 W for 150 ms
at $R_{coil} = 17.3\Omega$	0.5 A 4.4 W 0.65 Ws 0.74 A 10.5 W 1.55 Ws 12 A 23 W 3.4 Ws > 12 A 13.58 W 2.0 Ws
Remote tripping:	

Flag indicator

Rated voltage:	24 V $\pm 10\%$. The trip mechanism of the flag indicator (internal resistance $\square 400\square$) must be voltage-proof, because the voltage at the coil might be 200 V at the instant of a trip (200 V/20ms).
----------------	---

Mains part

Rated voltage:	16 V - 200 VDC
Power consumption:	16 V - 140 VAC <= 1.5 W at 24 VDC <= 1.2 W at 60 VDC <= 2.5 VA at 110 VAC

Battery:

Rated voltage:	3.0 V
Signal battery voltage too low at:	2.2 V
Min. operating voltage:	2.0 V
Life span storage:	10 years

Accuracy

Basic accuracy: ±5% related to the actual current measuring value

Basic accuracy of the trip time: ±3% or ±10 ms

Frequency effect deviation is In the range of ±5% of the rated frequency, the current deviation is 0.5% per Hz.

Dropout to pickup ratio: >97%

Temperature effect At -20°C +55°C = ±1.5%

Climatic withstand

Storage: -40°C ... +85°C

Operation: -20°C ... +55°C

Output relays

The relay 2 and watchdog relays have the following characteristics:

Load	Ohmic Load (cos φ = 1)	Inductive Load (cos φ = 0,4 L/R = 7 ms)
Rated load	250 VAC 16 A 400 VAC 7 A 30 VDC 16 A	250 VAC 8 A 400 VAC 3,5 A 30 VDC 8 A
Making current	16 A	
Max. contact voltage	400 VAC, 125 DC	
Max. contact current	16 A	
Max. breaking capacity	AC 4000 VA DC 480 W	AC 2000 VA DC 240 W

mechanical life span: 30 x 10⁶ operating cycles
 electrical life span: 2 x 10⁵ operating cycles at 220 V AC/6 A
 Contact material: silver cadmium oxide (AgCdO)

Electrical and mechanical features of the relay 1

Max. operating capacity 400 V AC/2650 VA/continuous current 10 A
 (acc. to DIN VDE 435)
 mechanical life span: 1 x 10⁶
 electrical life span: 1.2 x 10⁵ operating cycles at 230V AC/10A
 Contact material: silver-cadmium-oxide (AgCdO)
 Minimum operating time ca. 10 ms
 Returning time: ca. 10 ms
 Test voltage: 4000 V AC eff

7.1 System data

Design standard:	
Generic standard:	EN 50082-2, EN 50081-1
Product standard:	EN 60255-6, IEC 255-4, BS 142
Specified ambient service	
Storage temperature range:	- 40°C to +85°C
Operating temperature range:	- 20°C to +55°C
Environmental protection class F as per DIN 40040 and per DIN IEC 68 2-3:	relative humidity 95% at 40°C for 56 days
Insulation test voltage, inputs and outputs between themselves and to the relay frame as per EN 60255-6 and IEC 255-5:	2.5 kV (eff.), 50 Hz; 1 min
Impulse test voltage, inputs and outputs between themselves and to the relay frame as per EN 60255-6 and IEC 255-5:	5 kV; 1.2/50 µs; 0.5 J
High frequency interference test voltage, inputs and outputs between themselves and to the relay frame as per EN 60255-6 and IEC 255-22-1:	2.5 kV/1MHz
Electrostatic discharge (ESD) test as per EN 61000-4-2 and IEC 255-22-1:	8 kV air discharge, 6 kV contact discharge
Electrical fast transient (Burst) test as per EN 61000-4-8 and IEC 801-4:	4 kV/2.5 kHz, 15 ms
Power frequency magnetic field immunity test:	100 A/m continuously 1000 A/m for 3 s
Radiated electromagnetic field disturbance test as per ENV 50140, IEC 255-22-3:	electric field strength: 10 V/m
Conducted electromagnetic field disturbance test as per test as per ENV 50141:	electric field strength 10 V
Surge immunity EN 61000-4-5:	4 kV
Radio interference suppression test as per EN 55011:	limit value class B
Radio interference radiation test as per EN 55011:	limit value class B
Mechanical tests:	
Shock:	class 1 acc. to DIN IEC 255 part 21-2
Vibration:	class 1 acc. to DIN IEC 255 part 21-1
Degree of protection:	Electronics: IP40 Terminals: IP20
Material :	Macrolon 6030, self-extinguishing
Overvoltage class:	III

7.2 Setting ranges and steps

	Setting range	Step	Tolerance
I>	WIP1-1 0.5...2.5 A (EXIT) WIP1-2/WIP1-3 0.2...2.5 A (EXIT)	0.01; 0.02; 0.05; 0.005; 0.01; 0.02; 0.05;	±5% of setting value ±5% of setting value
t _{i>}	0.06 - 300 s (definite time) 0.05 -10 (inverse time)	0.01; 0.02; 0.1; 0.2; 0.5; 1.0; 2.0; 5.0; 10; 20 s 0.01; 0.02; 0.05; 0.1; 0.2; 0.5	±3% or ±10 ms ±5% for normal inverse ±7.5% for very and extremely inverse and X ² - X ⁴
t _{min}	0,06... 2 s	0.01 s; 0.02 s; 0.05 s	±3% or ±20 ms*
I>>	1... 35 A (EXIT)	0.02; 0.05; 0.1; 0.2; 0.5; 1.0 A	±3% of setting value or min. ±1% I _n
t _{i>>}	0.06... 2 s	0.01 s; 0.02 s; 0.05 s	±3% or ±10 ms

Table 7.1: Setting ranges phase current element

* Currents in the range from 0.5 to 1.5 A lead to trippings with increased trip delays (up to 50 ms).
If a C.T. current >0.5 A was present before tripping, the trip delay decreases (about 20 ms).

	Setting range	Step	Tolerance
I _{E>}	0.05...2.0 A (EXIT)	0.001; 0.002; 0.005; 0.01; 0,02	±3% of setting value or min. ±1% I _n
t _{i_{E>}}	0.06 - 300 s (definite time) 0.05 -10 (inverse time)	0.01; 0.02; 0.1; 0.2; 0.5; 1.0; 2.0; 5.0; 10; 20 s 0.01; 0.02; 0.05; 0.1; 0.2; 0.5	±3% or ±20 ms ±5% for normal inverse ±7,5% for very and extremely inverse
t _{min}	0.05... 2 s	0.01 s; 0.02 s; 0.05 s	±3% or ±10 ms
I _{E>>}	0.1... 9 A (EXIT)	0.02; 0.05; 0.1; 0.2; 0.5 A	±3% of setting value or min. ±1% I _n
t _{i_{E>>}}	0.06... 2 s	0.01 s; 0.02 s; 0.05 s	±3% or ±10 ms

Table 7.2: Setting ranges earth current element

Annotation to WIP1-1:

The earth fault current element is only activated if the current flowing in at least one of the phases is higher than the lowest adjustable threshold of the phase overcurrent element (0,5 A).

Technical data subject to change without notice!

7.3 Inverse time tripping characteristics

Tripping characteristics acc. to IEC 255-4 for phase and earth current element

Normal Inverse (Type A)

$$t = \frac{0.14}{\left(\frac{I}{I_S}\right)^{0.02} - 1} \cdot t_I > [s]$$

Very Inverse (Type B)

$$t = \frac{13.5}{\left(\frac{I}{I_S}\right) - 1} \cdot t_I > [s]$$

Extremely Inverse (Type C)

$$t = \frac{80}{\left(\frac{I}{I_S}\right)^2 - 1} \cdot t_I > [s]$$

Long Time Inverse

$$t = \frac{120}{\left(\frac{I}{I_S}\right) - 1} \cdot t_I > [s]$$

RI-Inverse Time

$$t = \frac{1}{0.339 - \frac{0.236}{\left(\frac{I}{I_S}\right)}} \cdot t_I > [s]$$

Where: t = tripping time
 tI > = time multiplier
 I = fault current
 IS = setting value of the current

Tripping characteristic for phase current elementX²- Tripping delay:

$$t = \frac{100}{\left(\frac{I}{I_S}\right)^2} \cdot t_{I>} [s]$$

X^{2.5}- Tripping delay:

$$t = \frac{100}{\left(\frac{I}{I_S}\right)^{2.5}} \cdot t_{I>} [s]$$

X³- Tripping delay:

$$t = \frac{100}{\left(\frac{I}{I_S}\right)^3} \cdot t_{I>} [s]$$

X^{3.5}- Tripping delay:

$$t = \frac{100}{\left(\frac{I}{I_S}\right)^{3.5}} \cdot t_{I>} [s]$$

X⁴- Tripping delay:

$$t = \frac{100}{\left(\frac{I}{I_S}\right)^4} \cdot t_{I>} [s]$$

7.3.1 Tripping characteristics

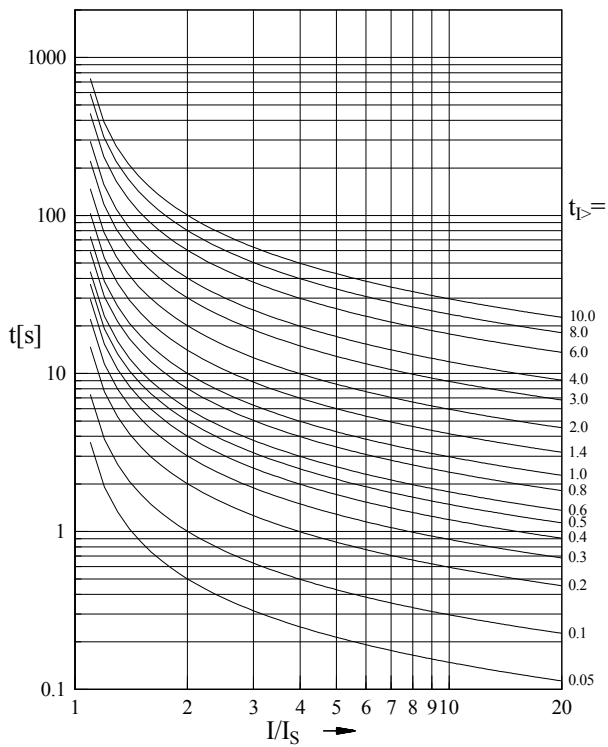

Figure 7.1: Normal inverse tripping characteristic

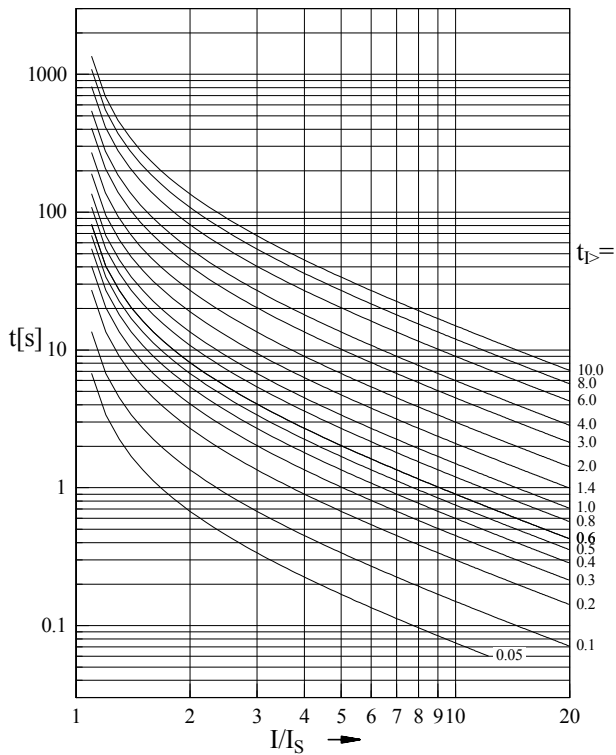

Figure 7.2: Very inverse tripping characteristic

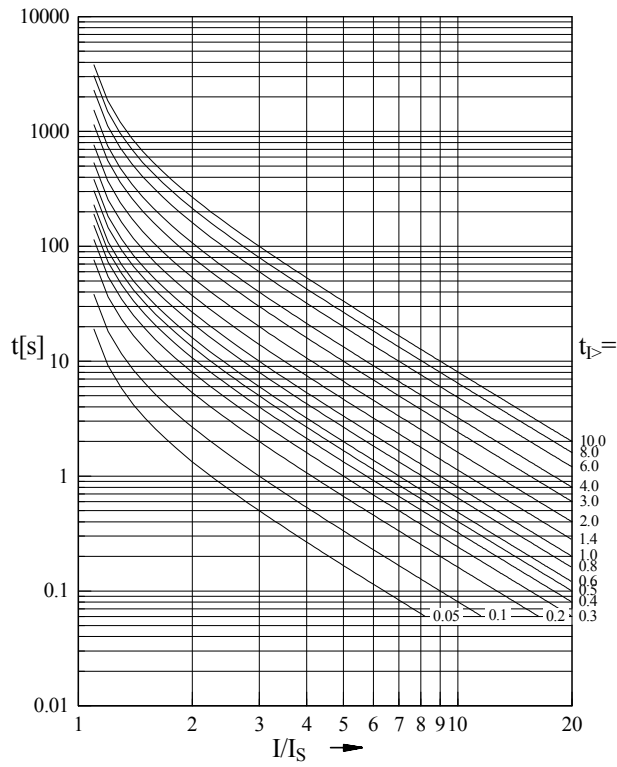

Figure 7.3: Extremely inverse tripping characteristic

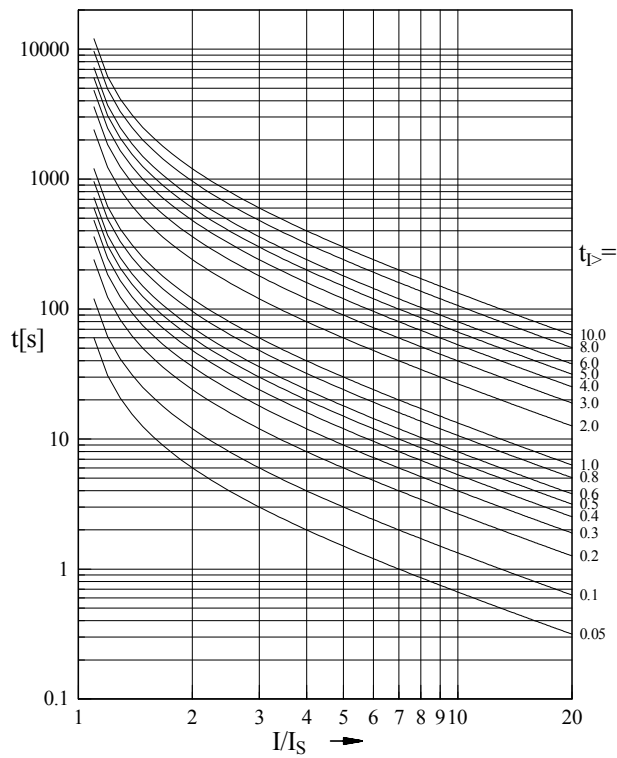

Figure 7.4: Long Time Inverse

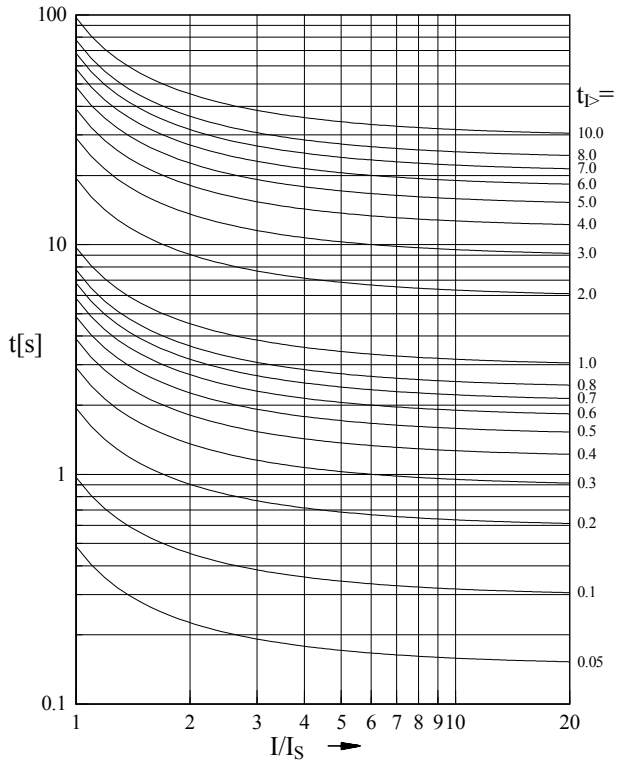

Figure 7.5: Ri-Inverse

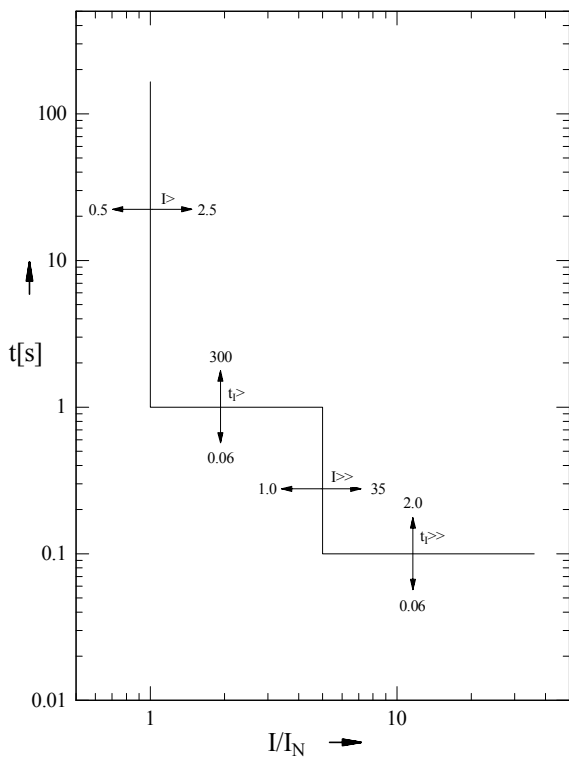

Figure 7.6: Definite time tripping characteristic

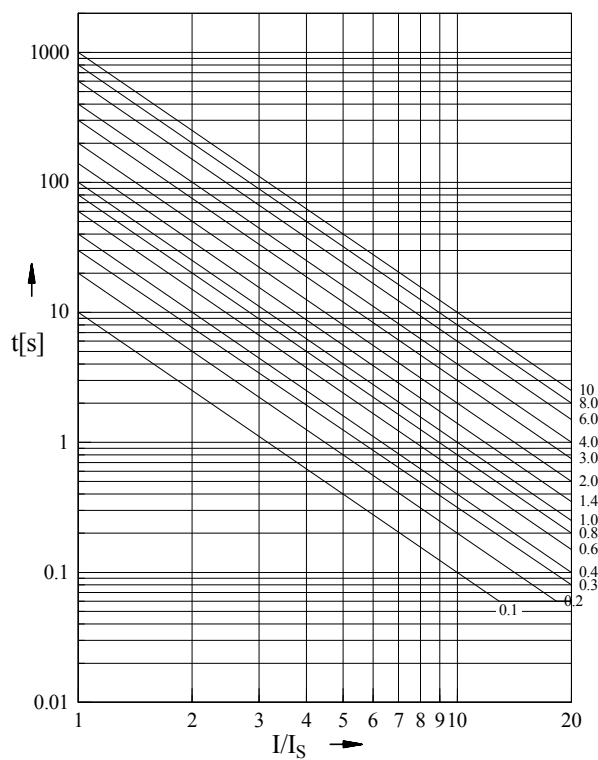

Figure 7.7: x^2 - tripping characteristic

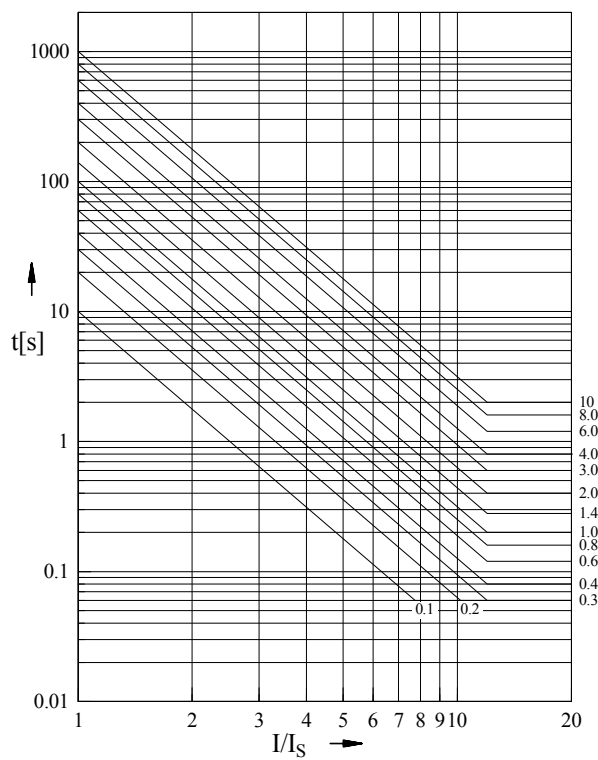

Figure 7.8: $x^{2.5}$ - tripping characteristic

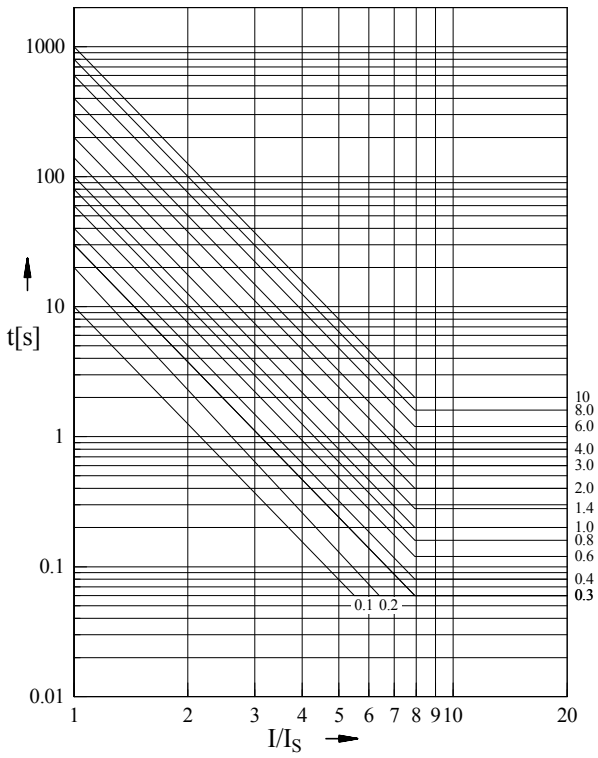

Figure 7.9: x^3 - tripping characteristic

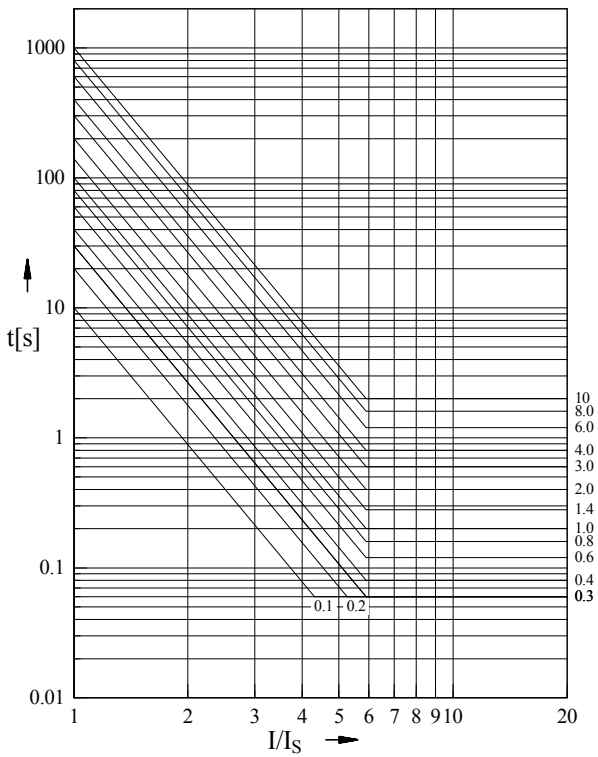

Figure 7.10: $x^{3.5}$ - tripping characteristic

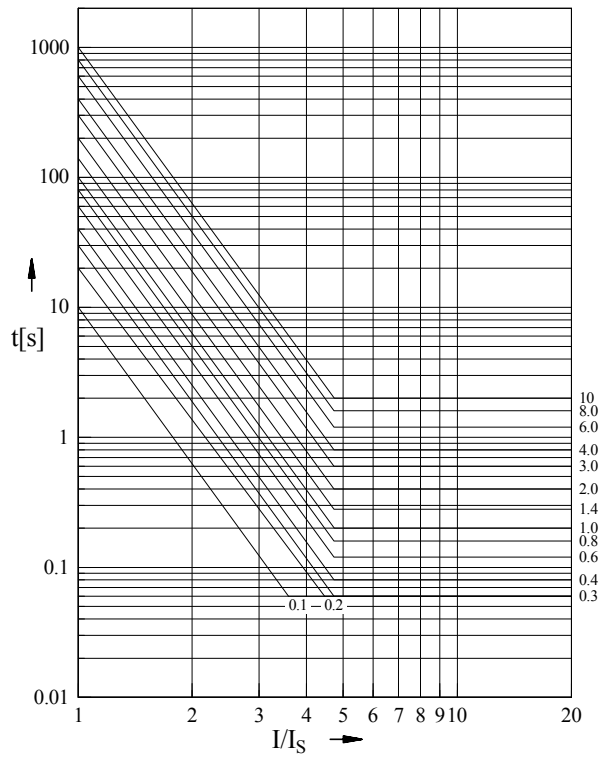

Figure 7.11: x^4 - tripping characteristic

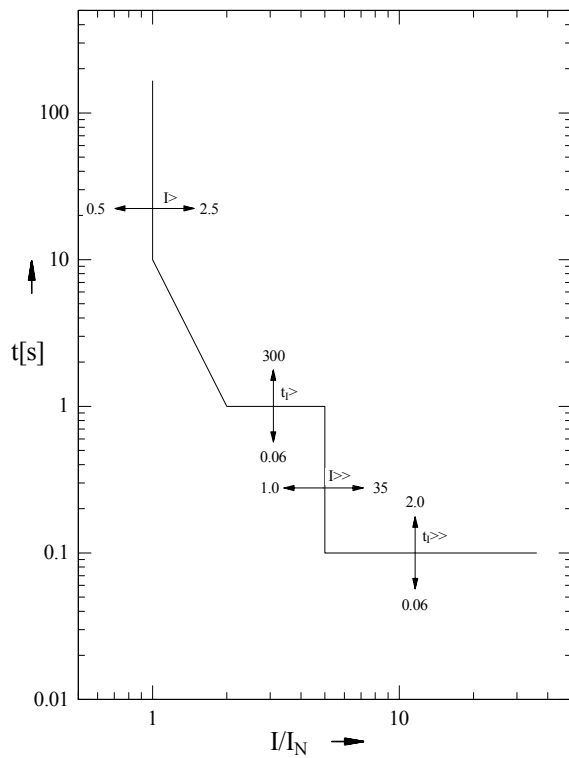

Figure 7.12: Setting example: Overcurrent setting with short circuit function and limiting the tripping characteristic

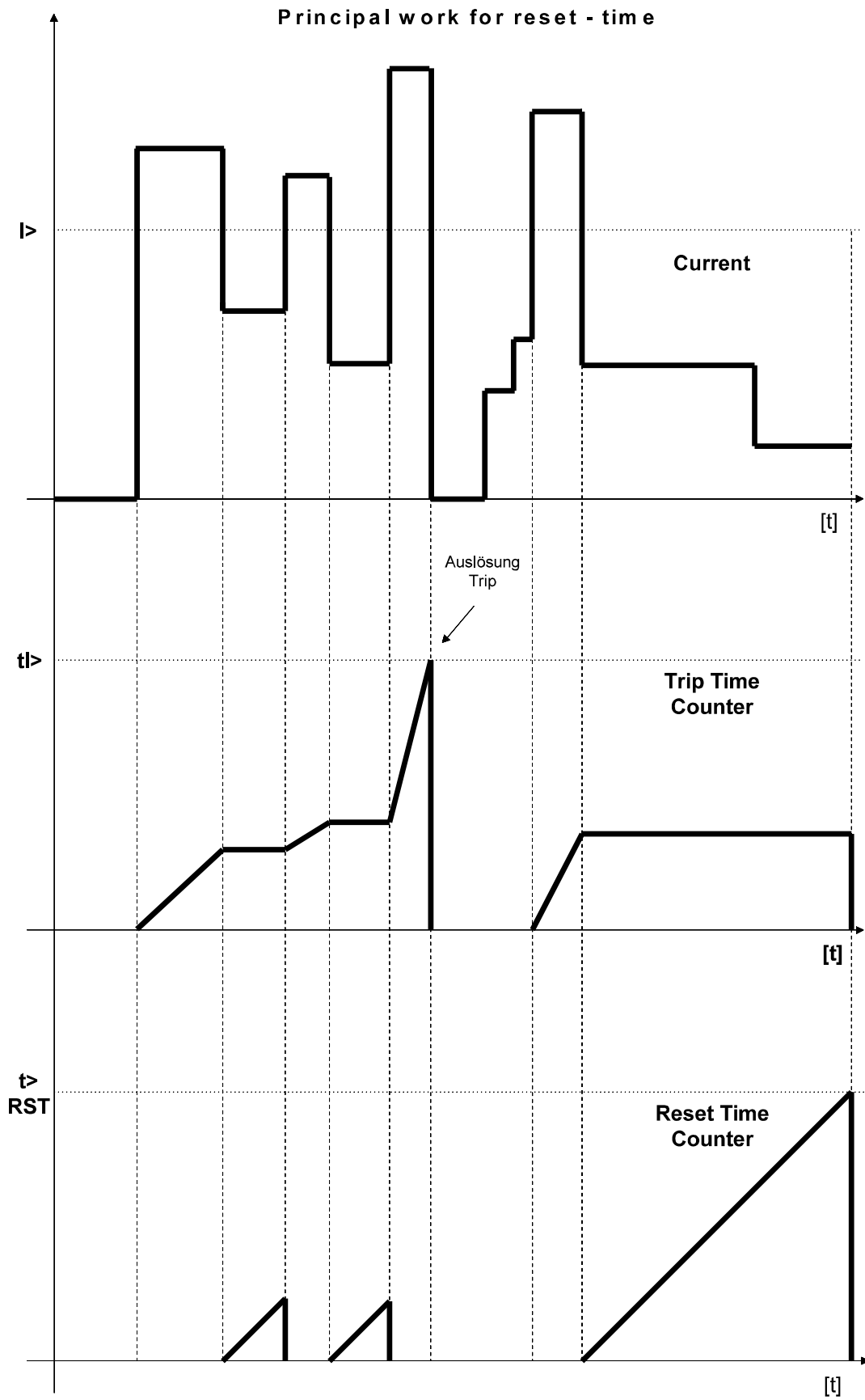

Figure 7.13: Trip example

7.4 Relay case

Relay WIP1 is designed to be fastened onto a DIN-rail acc. to DIN EN 50022.
The front plate of the relay is protected with a sealable transparent cover (IP40).

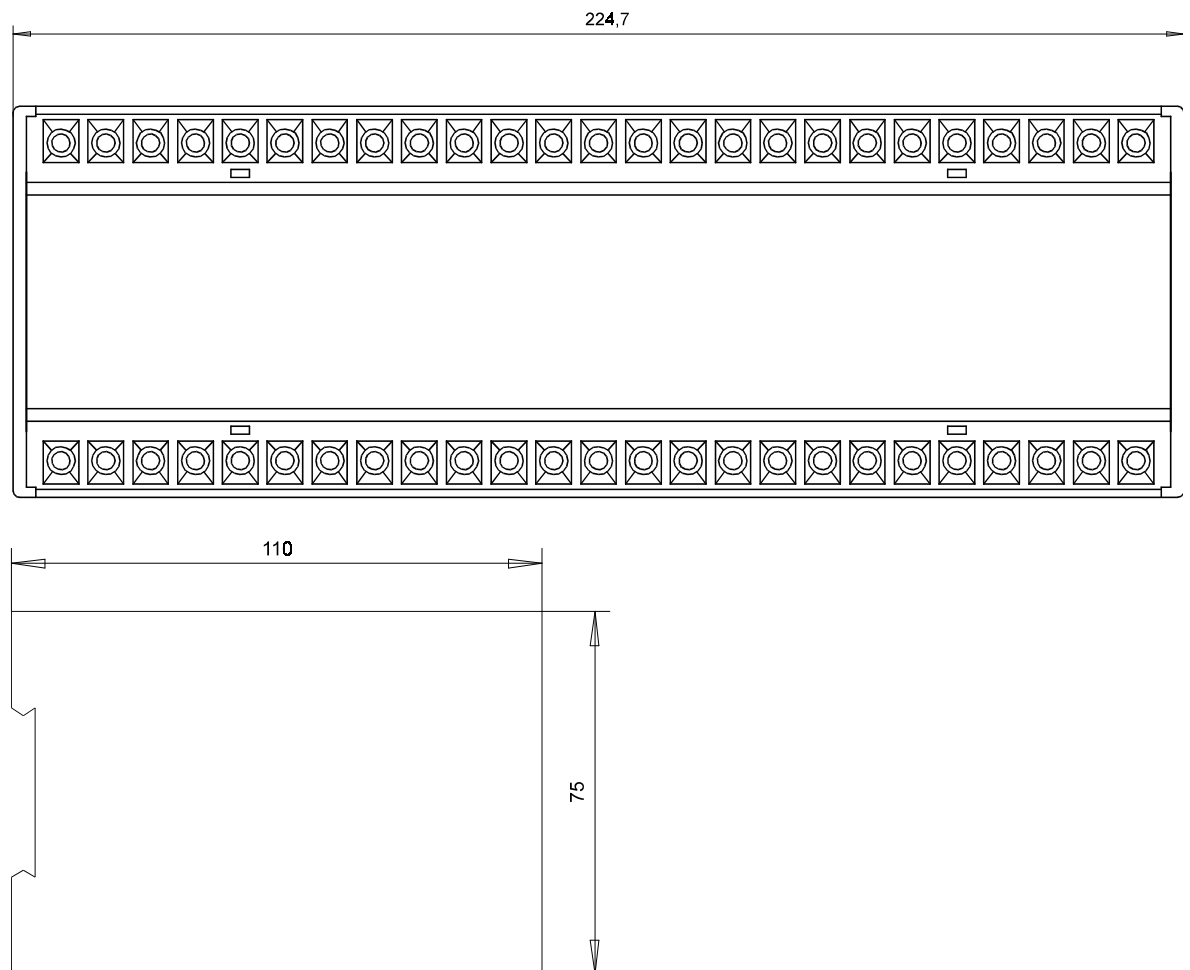

Figure 7.14: Dimensions WIP1 in mm

Connection terminals

The connection of up to a maximum of $2 \times 2.5 \text{ mm}^2$ cross-section conductors is possible. For this the transparent cover of the unit has to be removed (see chapter 4).

7.5 Flag indicators

Flag indicator WI1-SZ2

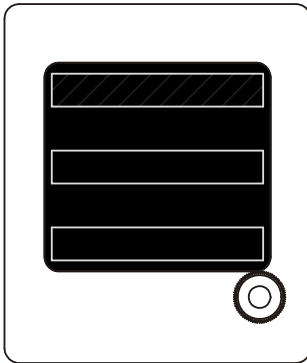

Kein Fehler angezeigt
No fault indication

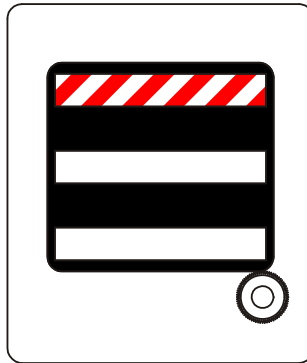

Fehler
Fault

Kontakt 1 = + (an Klemme 11)
Kontakt 2 = - (an Klemme 12)
Innenwiderstand $R_i = 600\Omega$

Contact 1 = + (to terminal 11)
Contact 2 = - (to terminal 12)
Internal resistance $R_i = 600\Omega$

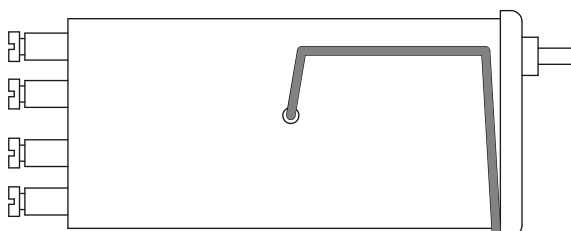
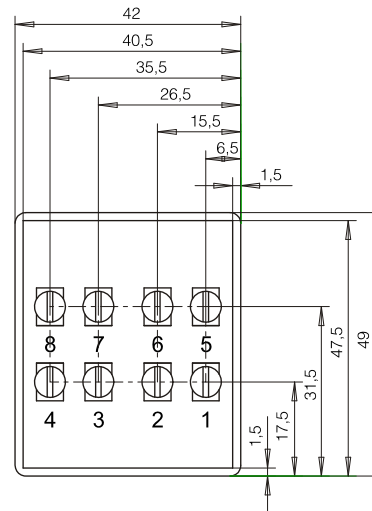
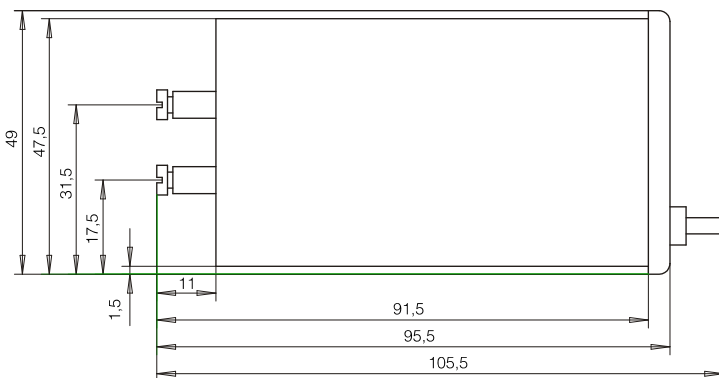

Maße : mm
dimensions : mm

Flag indicator WI1-SZ4

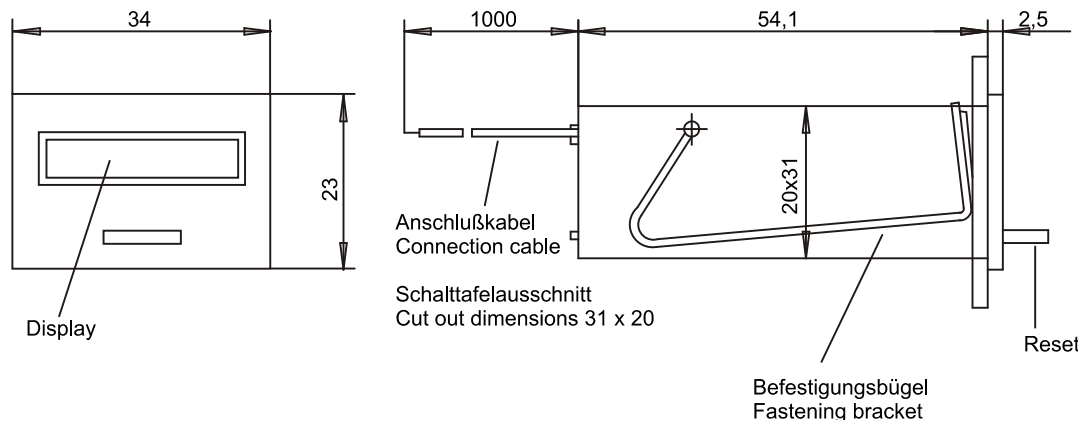

panel cut-out: 31 x 20 mm

8. Order form

Time overcurrent relay with multi-characteristic, self-powered	WIP1		I1		
3-phase current I>;I>>					
Self-powered	1				
Self-powered with additional power supply ¹ for 140 V AC resp. 200 V DC	2				
Self-powered with additional power supply ¹ , with RS485 interface	3				
Rated current	1 A				
Without earth current measuring (only possible for WIP1-1)				*	
With additional earth current measuring I _{E>} ; I _{E>>} Rated current 1A				E1	
Standard (PRO OPEN DATA Protocol)					*
Communication with MODBUS RTU Protocol (Possible with interface only)					M

* Please leave box empty if option is not desired

¹ The power pack serves as the device's own supply, it does not supply the tripping energy for the impulse output

Flag indicator WI1-SZ2	yes		no	
Flag indicator WI1-SZ4	yes		no	

230 V/AC Voltage supply	WIP1	PS
Connection of WIP1-2/3 to 230 V/AC mains		

Spare batteries

3.6 V spare battery	WIP1	BAT1
WIP1-1 and WIP1-2 to relay version G009		

3.0 V spare battery	WIP1	BAT2
----------------------------	-------------	-------------

*You can find the device version on the name plate

Setting list WIP1

Note !

All settings must be checked at site and should the occasion arise, adjusted to the object/item to be protected.

Project: _____ SEG job.-no.: _____

Function group: = _____ Location: + _____ Relay code: - _____

Relay functions: _____ Password: _____

Date: _____

System parameters

Parameter	Unit	Default setting	Actual setting	WIP1-1	WIP1-2	WIP1-3
Language		English		X	X	X
Password		++++		X	X	X
Date setting*		01.01.1990		X	X	X
Time setting*		00:00:00		X	X	X
Rated frequency	Hz	50		X	X	X
Slave address		1				X
Baud rate**		9600				X
Setting the parity**		even				X

* Actual setting at delivery ** Modbus protocol only

Protection parameters

Parameter	Unit	Default setting	Actual setting	WIP 1-1	WIP 1-2	WIP 1-3
Overcurrent pickup value	A	0.5		X	X	X
Selection of tripping characteristic (phase current element)		Definite Time		X	X	X
Overcurrent trip delay	s	0.06		X	X	X
Reset-Mode for inverse time tripping characteristics	s	0		X	X	X
Minimum tripping time (phase current element)	s	0.06		X	X	X
High set overcurrent value	A	1.0		X	X	X
Time delay for high set overcurrent	s	0.06		X	X	X
Earth fault current pickup value	A	0.05		X	X	X
Selection of characteristic (earth fault element)		Definite Time		X	X	X
Trip delay for earth fault current	s	0.06		X	X	X
Reset mode for inverse time tripping characteristics	s	0		X	X	X
Minimum tripping time (earth fault element)	s	0.05		X	X	X
Pickup value of earth fault high set element	A	0.1		X	X	X
Time delay for earth fault high set element	s	0.06		X	X	X

Kind of tripping

Specification	Unit	Default setting	Actual setting	WIP1-1	WIP1-2	WIP1-3
Reset		Manual		X	X	X
*Tripping via electro pulse or relay		Relay		X	X	X
Kind of tripping for IE> range		Trip		X	X	X
Trip-LED		Flashing		X	X	X

* When using a tripping coil the parameter has to be set to „Electro pulse“.

Relay matrix

Specification	Unit	Default setting	Actual setting	WIP1-1	WIP1-2	WIP1-3
Overcurrent I> Alarm		No			X	X
Overcurrent I> Trip		YES		X	X	X
Short circuit I>> Alarm		No			X	X
Short circuit I>> Trip		YES		X	X	X
Earth fault overcurrent IE> Alarm		No			X	X
Earth fault overcurrent IE> Trip		YES		X	X	X
Earth short circuit IE>> Alarm		No			X	X
Earth short circuit IE>> Trip		YES		X	X	X

Signal inputs

Function	Default settings		Actual setting		WIP1-1	WIP1-2	WIP1-3
	Blocked	Not blocked	Blocked	Not blocked			
I>		X			X	X	X
I>>	X				X	X	X
IE>		X			X	X	X
IE>>		X			X	X	X

Fast tripping	Default settings		Actual setting		WIP 1-1	WIP 1-2	WIP 1-3
	Instantaneous	After activation	Instantaneous	After activation			
	X				X	X	X

The present unit descriptions shall be valid as of software version no.:

WIP1-1: V02-1.11

WIP1-2: V12-1.16

WIP1-3: V13-1.06

**SEG****Woodward SEG GmbH & Co. KG**

Krefelder Weg 47 · D – 47906 Kempen (Germany)
Postfach 10 07 55 (P.O.Box) · D – 47884 Kempen (Germany)
Phone: +49 (0) 21 52 145 1

Internet

Homepage <http://www.woodward-seg.com>
Documentation <http://doc.seg-pp.com>

Sales

Phone: +49 (0) 21 52 145 635 · Telefax: +49 (0) 21 52 145 354
e-mail: kemp.electronics@woodward.com

Service

Phone: +49 (0) 21 52 145 614 · Telefax: +49 (0) 21 52 145 455
e-mail: kemp.pd@woodward.com